

Smart-Tech® High Capacity Forward Clutch Drum Kit

Part No.

76655-01K

- Drum
- Bottom Steel Plate .055" thick

Patent No. 9,562,573



WARNING: Cannot be used with '04-'05 riveted style sun gear shell. For applications with front speed sensor and riveted style sun shell, replace sun shell with later design without rivets (OE Part No. 5L3Z7A019AB) or aftermarket equivalent.

Ford 4R70E, 4R70W, 4R75E, 4R75W, AOD, AODE



1. Disassembly

- Before removing OE input shaft, record measurement from either end of the input shaft to the drum (**Figure 1**).
- Press input shaft out of OE forward drum.

2. Installation & Assembly

- Before pressing OE input shaft into Sonnax forward drum, support the center of the drum as shown (**Figure 1**).
- Use an appropriate high-pressure lubricant (STP® oil treatment, 80/90 gear oil, or equivalent) when pressing the parts together.
- Press OE shaft into Sonnax drum until the shaft-to-drum measurement is equal to that recorded in disassembly step 1a.

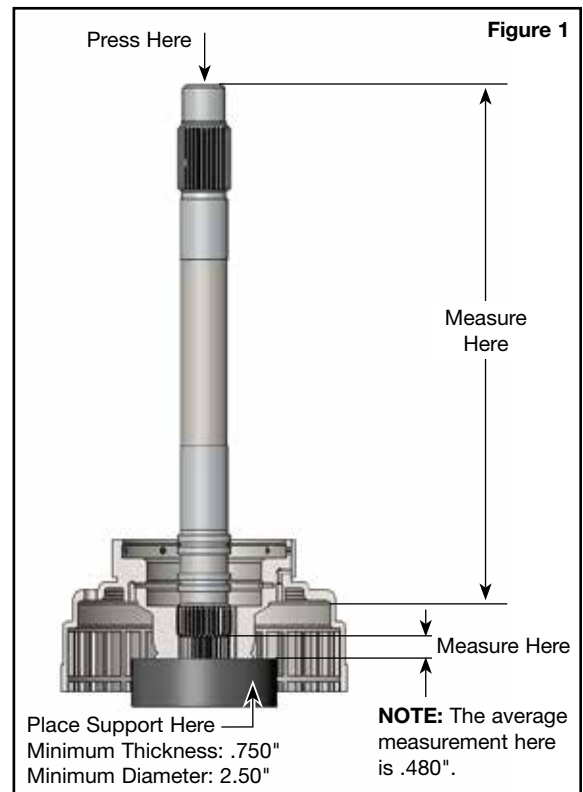

3. Clutch Assembly Information

OE recommended clutch clearance is .010–.014" per friction. Some high-performance builders prefer .006–.010" clearance per friction. Due to the limited space available for increasing the number of clutches, this kit includes one thinner (.055" thick) steel.

- Assemble clutch pack, backing plate and retaining ring (**Figure 2**).
- Check clutch clearance with feeler gage by applying slight downward pressure on backing plate while checking clearance between retaining ring and backing plate.
- Clutch clearance can be adjusted by three methods:
 - Change selective thickness retaining ring (**Figure 3**).



WARNING: with late style (non-riveted) non-ferrous sun shells check clearance between backing plate and inner area of sun shell if using a retaining ring thinner than .075" thickness.

- Machine the piston. Up to .030" can be machined off the bottom of the piston. For this application it is better to machine the bottom of the piston than the top as this moves the piston deeper in the housing bore and increases available seal travel.
- Change wave spring on early models. Early wave springs are .072" thick with approximately .180" height. Later springs are .082" thick with approximately .150" height. The later .082" thick with approximately .150" height can be used to replace the earlier .072" thick with approximately .180" height and increase clutch clearance.



WARNING: On late style (non-riveted) non-ferrous sun shells check clearance between backing plate and inner area of sun shell if using a retaining ring thinner than .075" thickness (OE discontinued, but can be salvaged from early cores).



NOTE: To replace an AOD cast forward drum requires updating related components with AODE versions. Update forward clutch pack with AODE style friction, steel & waved plates, backing plate and retaining ring. Additionally, either (1) machine tips of reluctor from forward drum, OR (2) update sun gear shell and reverse drum with AODE versions. See warning regarding riveted sun gear shell.

Smart-Tech high capacity forward clutch drum kit with 6 frictions.

Figure 2

- OE Retaining Ring
- OE-Thickness Friction Plates (6)
- OE-Thickness Steel Plates (6)
- Waved Plate, .072" thick

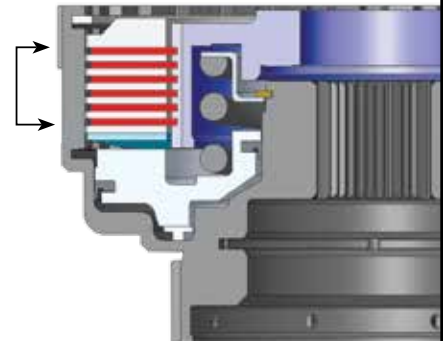

20% Increased Capacity

Figure 3

Retaining Rings	OE Part Numbers	Thickness
	5L3Z-7D483-D	.094"
	5L3Z-7D483-C	.084"
	5L3Z-7D483-B	.075"
5L3Z-7D483-A	.070"	

Wave Spring	OE Part Number	Thickness
	XL3Z-7E085-AA	.082"



Use this Sun Shell with Sonnax Forward Clutch Drums

Figure 4



WARNING: Do NOT use!



Some models may come equipped with a riveted type sun shell design. Sonnax forward clutch drums are **NOT** compatible with this design due to clearance issues.