

Reverse Boost Valve Kit

Early Style

Part No.

63741-12K

- Sleeve
- Valve
- Spring

NOTE: Also fits Kia A5SR1/A5SR2.

Jatco/Nissan RE5R05A

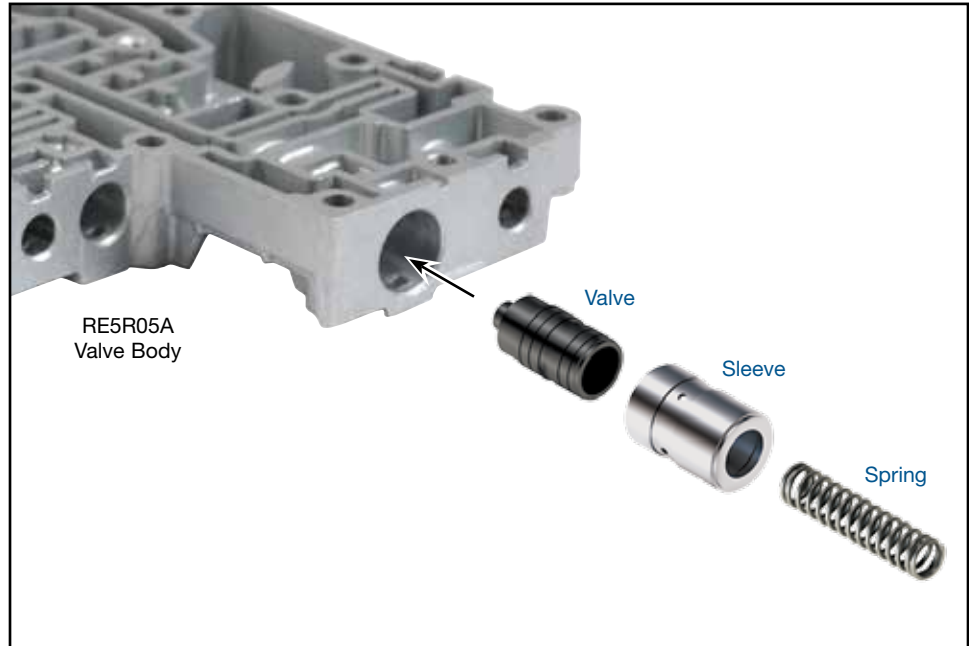

CAUTION: Verify whether early or late-style OE valve is equipped to select appropriate Sonnax kit (**Figure 1**).

1. Disassembly

- a. Remove OE spring retainer, keep for reuse.
- b. Remove and discard OE boost valve, sleeve and spring.

2. Installation & Assembly

- a. Install Sonnax boost valve and sleeve.
- b. Install Sonnax spring.
- c. Reinstall OE spring retainer.

3. Final Testing

Vacuum testing at the port(s) indicated holds the recommended minimum 18 in-Hg (**Figure 2**).

