

# 6L8-VL-PR3 Patent Pending Fixes 3 Transmissions



## Corrects/Prevents/Reduces

Extreme Pressure Damage Due to Worn PR Bore,  
Restores Proper Pressure Regulator Function.  
No Special Tools Required!

### Tech Note:

This land is purposely undersized for additional lube flow. This helps prevent engine chug while coasting to a stop, when hot.

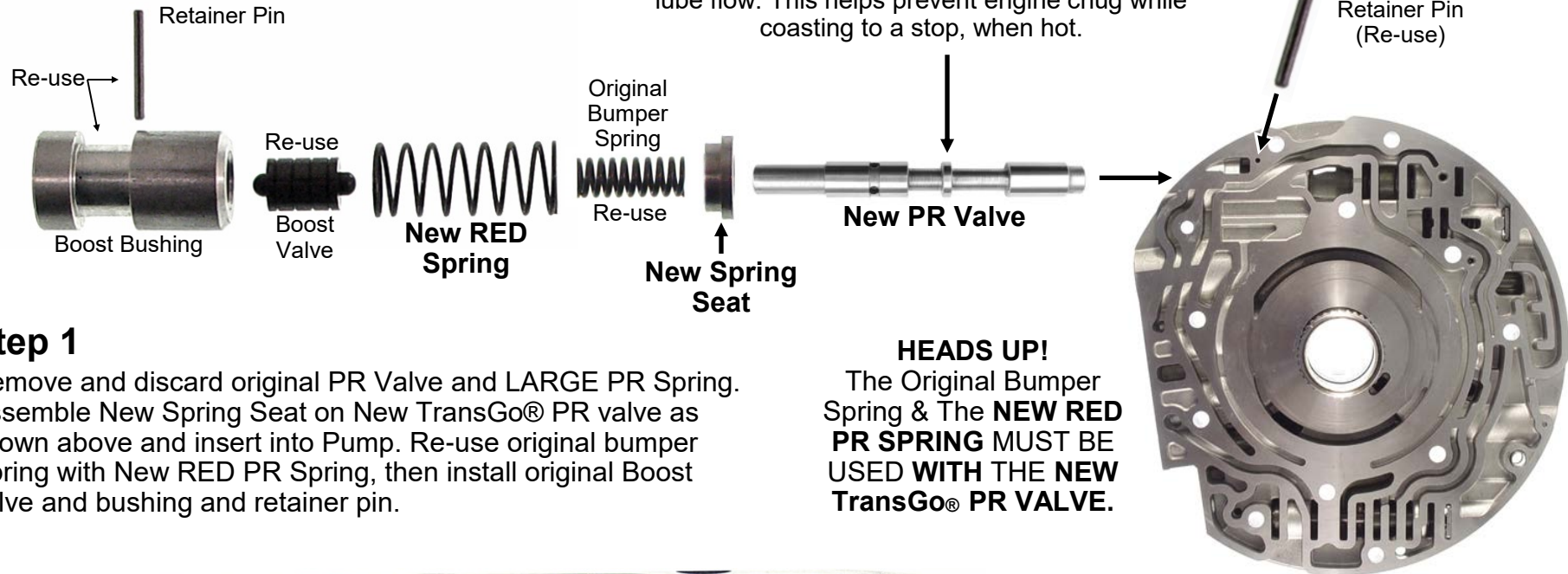

### Step 1

Remove and discard original PR Valve and LARGE PR Spring. Assemble New Spring Seat on New TransGo® PR valve as shown above and insert into Pump. Re-use original bumper Spring with New RED PR Spring, then install original Boost valve and bushing and retainer pin.

**HEADS UP!**  
The Original Bumper Spring & The **NEW RED PR SPRING** MUST BE USED WITH THE **NEW TransGo® PR VALVE**.

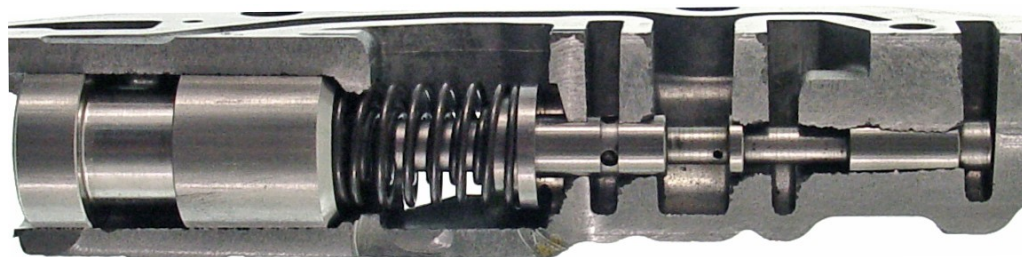

**Great News! New TransGo® PR Valve has additional support that restores proper valve function. EVEN IN A WORN BORE!**

Discard original PR Valve & Large PR Spring.



**See additional information!**



## Additional Information

The blowouts are easy to see.



1-2-3-4 Clutch Housing

### Watch for cracked pistons throughout this unit!

What breaks depends on what gear the trans was in when the extreme pressure malfunction occurs. The 1-2-3-4 clutch area shown is one of the more common areas to fail due to extreme pressure.

Complaints can be no 3rd, 5th, Reverse, Forward or falls out of gear at a stop when hot.

Look Carefully for Hairline Cracks



**Wash parts and blow dry with compressed air before looking for cracks! Keep a magnifying glass handy if you have less than youthful eyes!**

**WARNING! When replacing pistons and related parts, MAKE SURE they are the same diameter as parts your replacing. Differences can be as little as .045"!**

**LOOK CAREFULLY!**



1-2-3-4 Clutch Piston

## Additional Information

### 1,2,3,4 / 3-5-Rev Drum

Pay attention to the location of the Lower & Upper Snap-ring **Stop Lug** in the Drum. The **open ends** of each snap-ring **MUST** be located on either side of the lug. The lower and upper stops are located 180° opposite of each other in the drum.  
(Lug has no groove for snap-ring!)

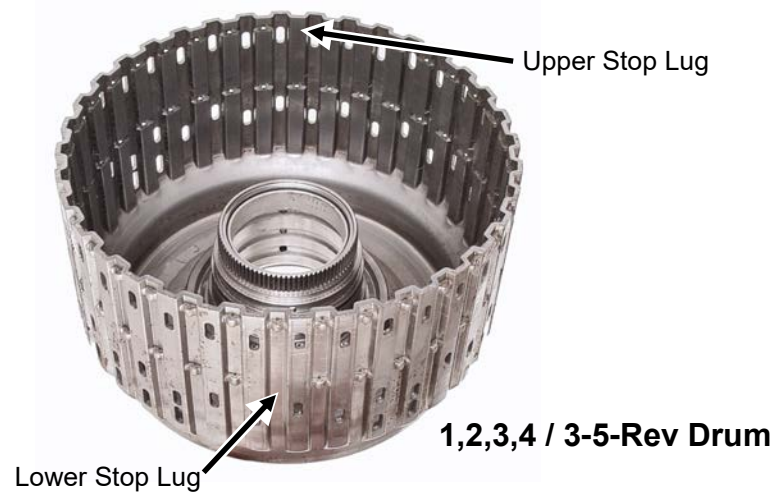
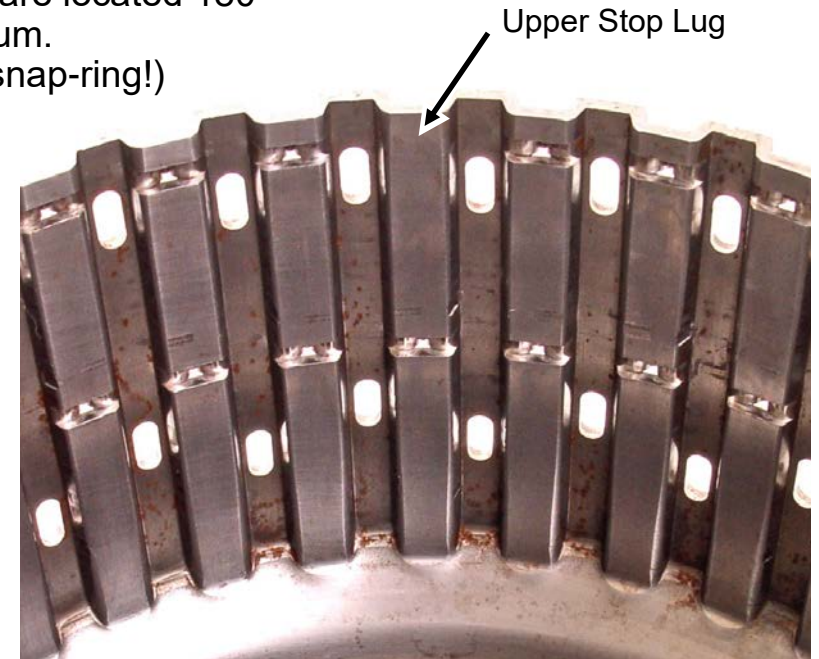
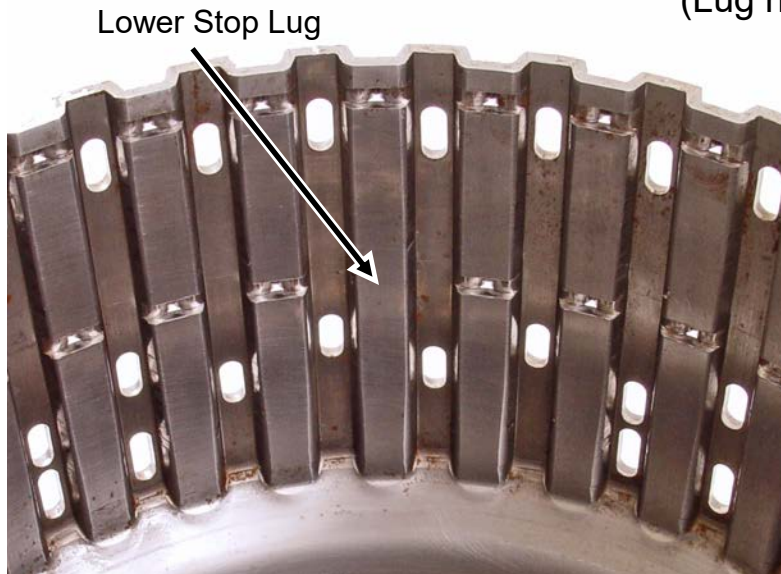

If mislocated, it may take as much as 3 weeks for the snap-ring to become dislodged & set solenoid performance codes. This is usually but not limited to complaints of no forward and or no reverse **after overhaul**.

## Additional Information

Look carefully for hairline cracks on the front of the drum! Hold it! You may need a magnifying glass to see the crack. At this time a loaded drum complete is approx \$285.00. In our opinion if the clutches were damaged or the vehicle had a Forward, 3rd, 5th or Reverse complaint, it's far safer to replace the drum as an assembly then risk the re-work.

High torque transfer or shift shock can damage the drum but not crack the pistons. However, it's the high pressure that can damage both the drum and or the pistons. Fixing the extreme runaway pressure is key to keeping the parts alive longer.



1,2,3,4 / 3-5-Rev Drum

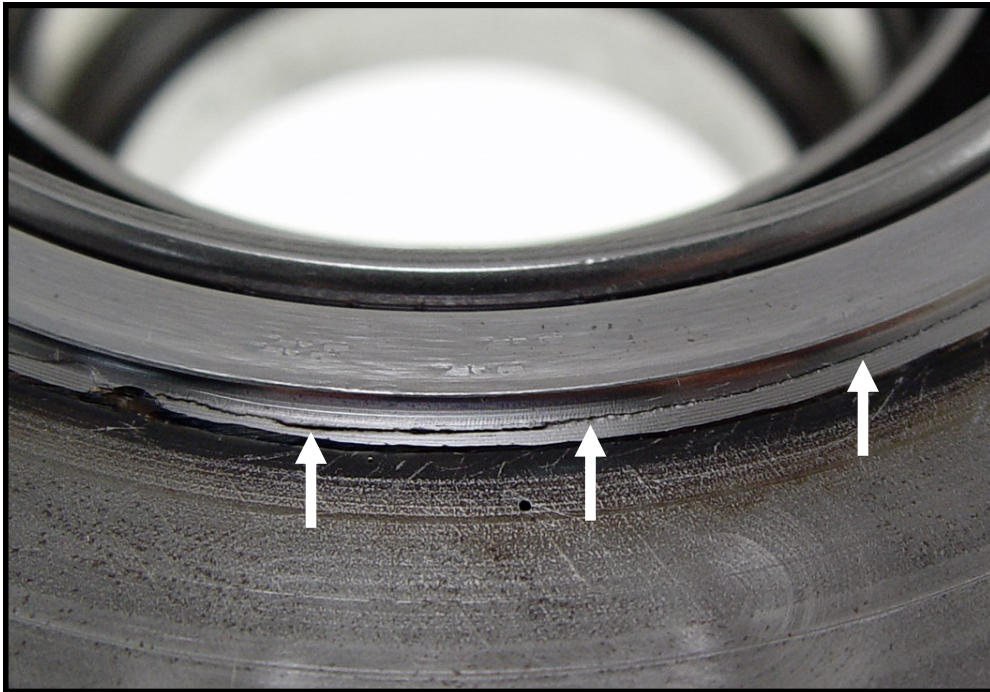

*Fixing the cause of the complaints is our goal. Making products to help you be more successful is the result of listening. Let us hear from you!*



**Mr. Shift**