

SK® KM175/77 Shift Kit®



Reduces/Corrects/Prevents

2-3 Cutloose and/or long soft 3rd—Front clutch burnup [3rd]
3-4 Neutral—4-2 Kickdown runaway—Coast Downshift Bang
Long slide 1-2 shift—Long 3-4—No Reverse or No forward
Won't fill converter—Low/No cooler flow—Wrong Fluid level.

If a 5/16" ball fits this hole, use it. If 5/16" doesn't fit hole, use a 7/32" [.215 to .218]

Pump

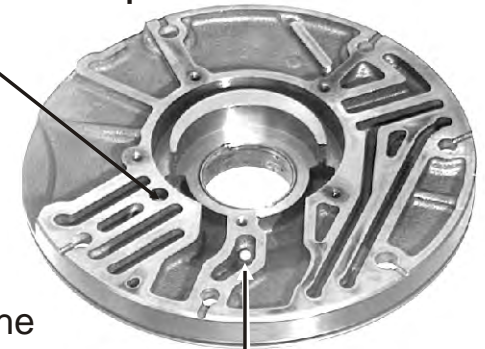

Reduce leak and seal blowing out: Enlarge the front seal drainback hole with 1/4" drill. It's OK if it drills a little bit of bushing.

Drill .210 to .228



Clean and blow dry the ring grooves. Install BOTH expander wires into the ring grooves. Fill grooves with Vaseline or Jel. Then squeeze rings into the groove and install pump gently. **Don't use Grease.** [Pat Pending]

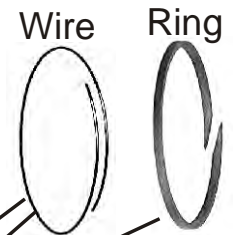

Pump Cover



Hello mechanic and Shop Owner

"High quality shops find this kit to be a basic upgrade for a satisfactory, no complaint, major repair. You'll be surprised at how good this trans will work.

Also: Shops report that Installing this kit from the bottom without removing the trans, by skipping pages 1 and 2 will often correct complaints in trans's that have already received a major o'haul or are not quite ready for a major o'haul." Thanks for listening, Gil

Each day your key tech person is working on one that won't ship or is back with a complaint reduces shop volume about \$1000. A good way to make more money is to get it right on the first try.

Fast Endplay Correction

Rear Drum

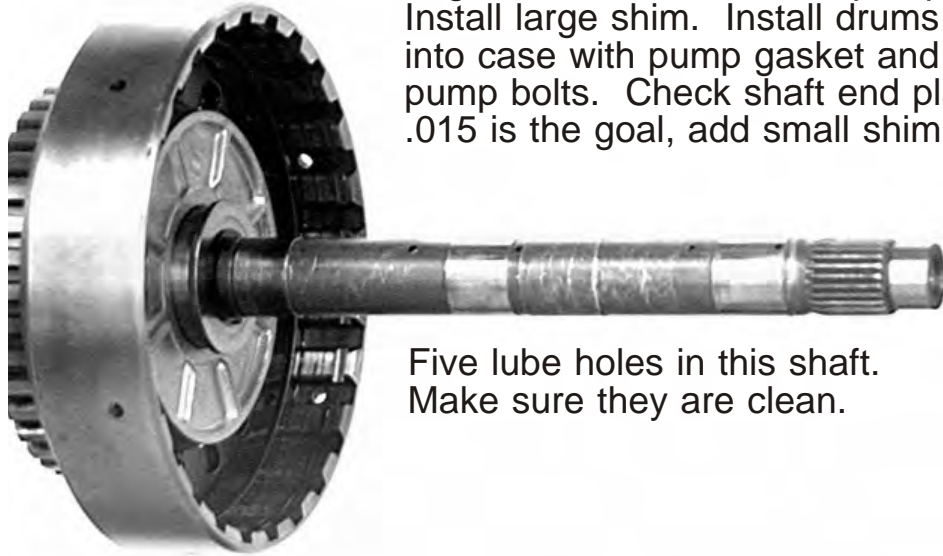

Endplay Shims: Shim(s) bring input shaft rings to correct location in pump stator. Install large shim. Install drums and pump into case with pump gasket and tighten two pump bolts. Check shaft end play .005 to .015 is the goal, add small shim if needed.

Five lube holes in this shaft. Make sure they are clean.

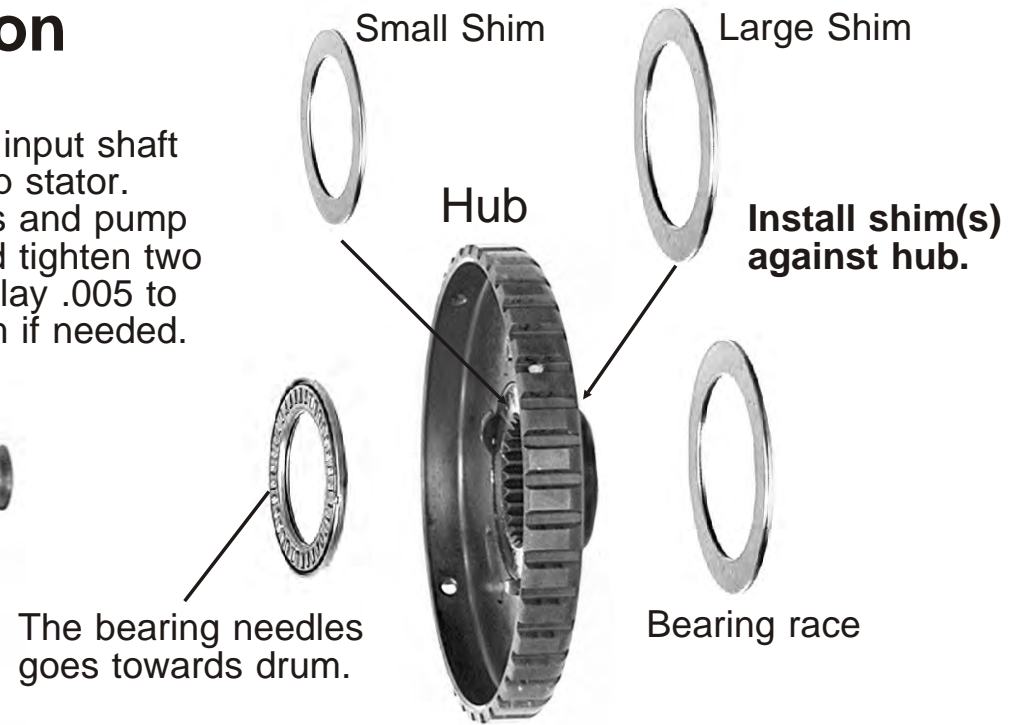

Listen Up: This trans is very sensitive to the type of friction plates installed in front clutch [3rd]. This is **especially important** in the models with only two friction plates in the front clutch [3rd]. **Also:** By hand, sand the glaze off the front clutch [3rd] steel plates.

Front Drum [3rd]

Front drum endplay is not fussy but must turn free with the pump bolts tight.



Your attention and these upgrades will make this trans work way better than new. A wonderful way to get more money is to deliver more VALUE. And that's what you're doing. So charge more.

Install the new springs shown.

Main Valve Body

****LISTEN:** If special rings furnished in this kit are installed **DON'T INSTALL WHITE** spring. Reuse original spring.



Late plug, Install Solid end first then the spring.



Early plug install as shown. No spring.



Converter Regulator Valve



Pressure Control



****EXPLANATION:** ONLY install the **WHITE** spring when you are installing this kit, from the bottom, in a trans without the special rings.

Thank you

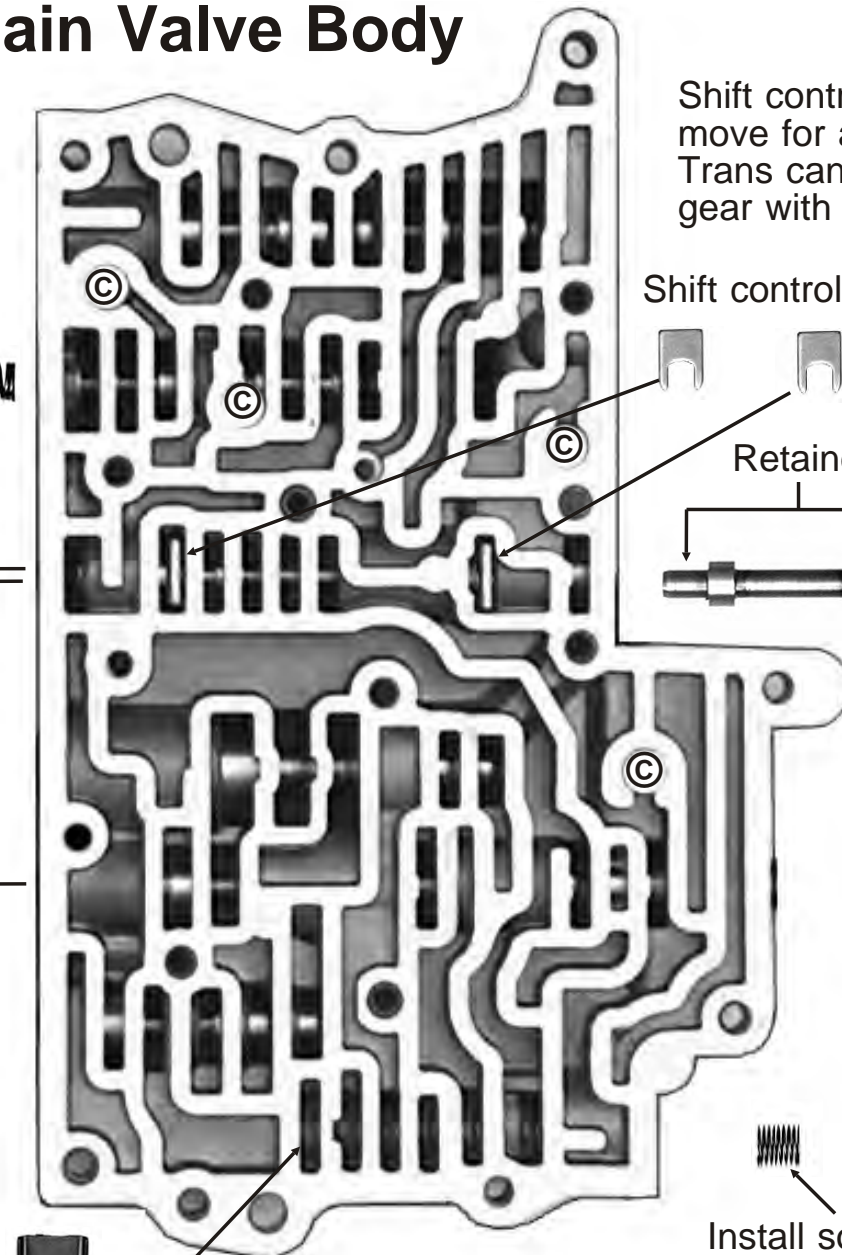

Shift control valve and plugs move for all up and down shifts. Trans can start and stay in any gear with a misassembly here.

Shift control valve retainers



Retainers must straddle the valve here.



Shift control valve.

© Install 4 Checkballs

Neutral-Drive Valve



Install solid wound spring.

If VB has a retainer here remove and discard it.

Auxiliary Valve Body

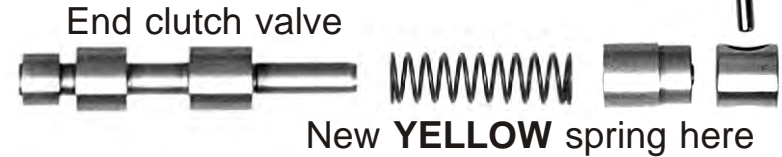
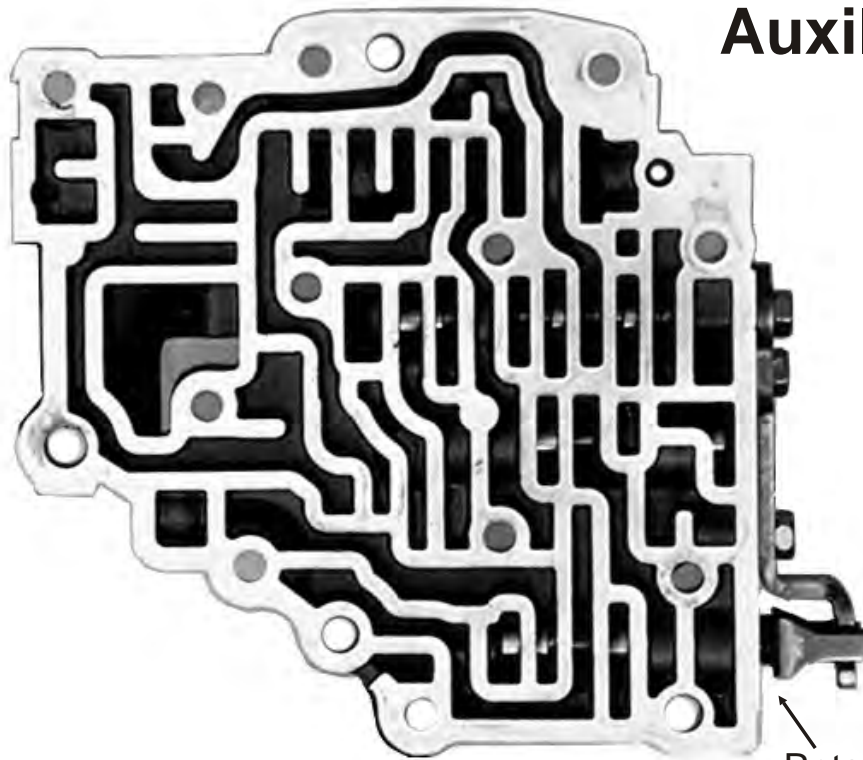

Reducing Pressure Adjustment
Turn screw until retainer plate is flush with VB, then back it off exactly 2 turns.



Retainer Plate

Manual Valve



There must not be a plug or a restrictor in the valve bore. If there is remove it.

Piston Housing

Locknut

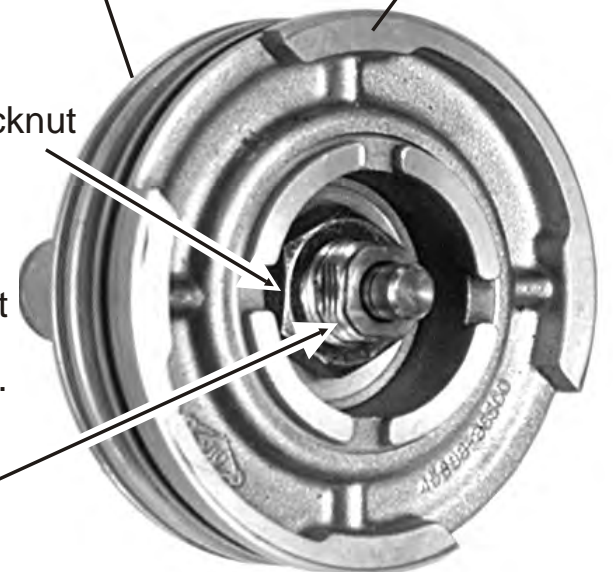

2-4 Band Adjust

Install return spring, piston, housing and the housing snap ring into the case. Loosen locknut. Turn servo pin until tight with a short wrench. Back off 2 1/4 turns and Tighten locknut.

Turn here with short wrench to adjust band.

Extremely Important
Fluid level must be checked in "N" or "D" and not in P or R. Here is how: With wheels off the ground on rack or with car against a telephone pole, run engine with selector in "N" just above an idle for 1/2 minute. Let idle in "N" and check level.

Plate Holes Sizes

Drill two holes with drill furnished. If either hole in the plate is bigger than the drill furnished, smack it smaller with a steel checkball and then re-drill it with the drill furnished.

Thank You,

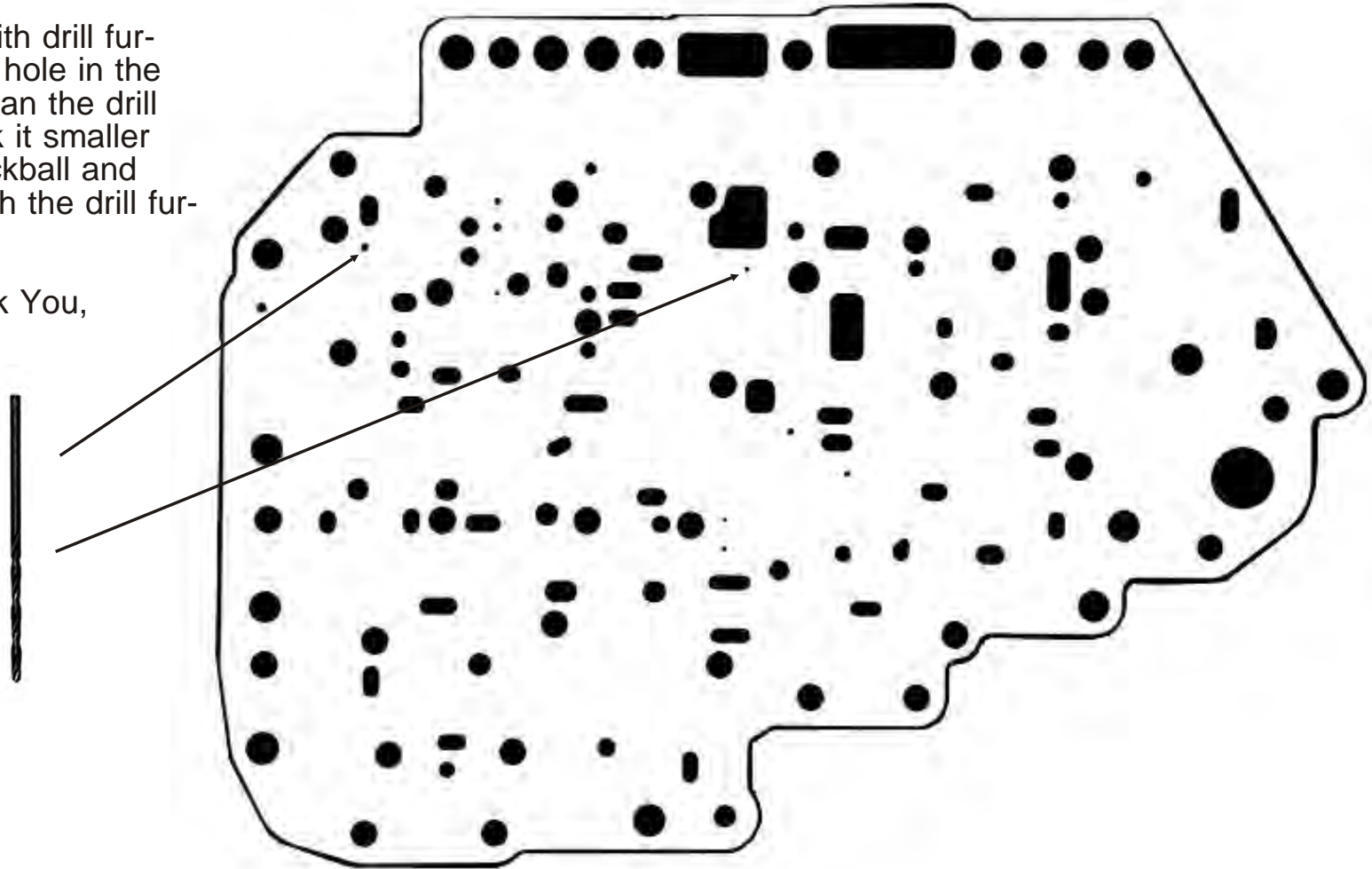

To Reduce Rework

Over tightening VB, AUX VB or filter bolts
WILL STICK VALVES: 50" lbs with 8MM
 socket and 80" lbs with 10mm. Disassemble
 AUX VB, clean and check valves for sticking.

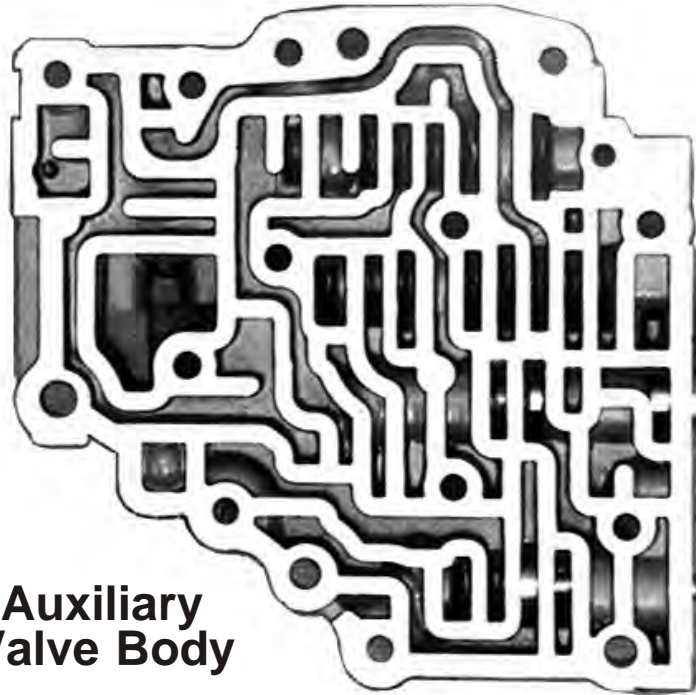

Auxiliary
Valve Body

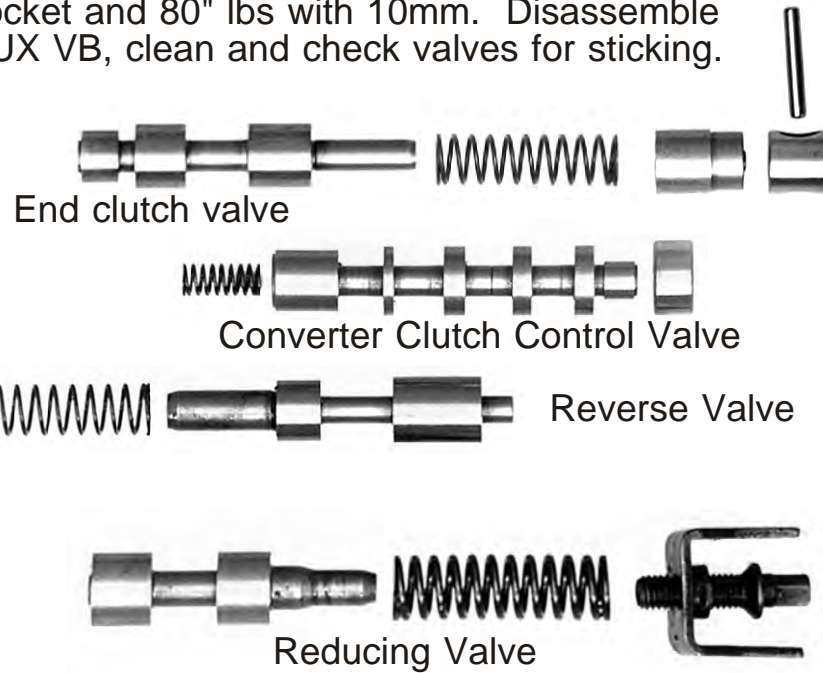

Cover Plate

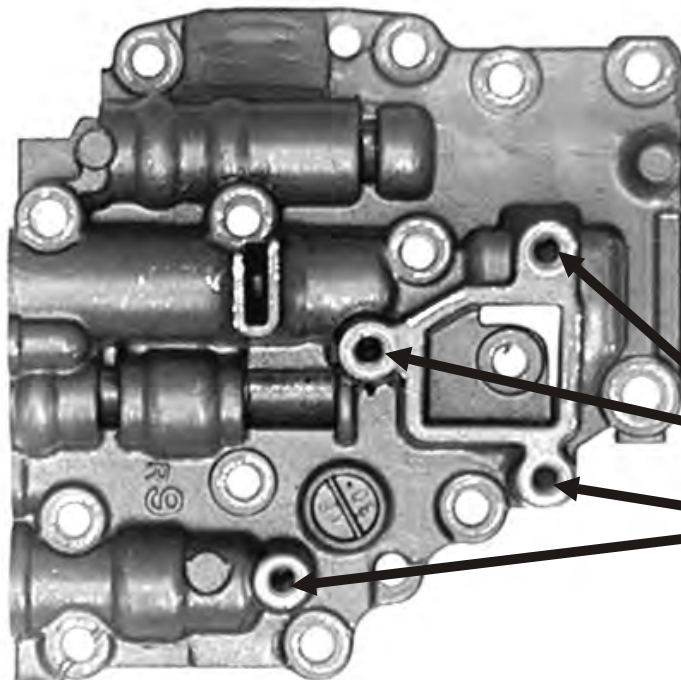

Short

Long

Stuck Valve Complaints

End clutch valve: 3-4 neutral.

Converter clutch control valve: Car won't move, No lube flow, Kills engine, has Drainback.

Reverse valve: Delayed reverse or no reverse.

Reducing valve: Rough shifts or band and front clutch burnup.

WARNING: Original filters use two long bolts and two short bolts. Some replacement filters may require four short bolts. If long bolts are used with these filters the bolts will bottom out in the casting and stick valves.

REDUCE FRONT SEAL LEAK or BLOWS OUT.
 Don't forget to enlarge front seal drainback hole.