

Performance Pack

Part No.

HP-4L60E-01

Fits '94-later units

Pump Parts

- Boost Valve with O-Ring, .490"
- Elevated Pressure Regulator Spring
- High RPM Pump Slide Spring
- Spacer

Servo Parts

- 4th Servo Return Spring
- Servo Cushion Spring
- Servo Piston D-Ring Kit

Case Parts

- 3-4 Accumulator Piston Kit
- 3-4 Accumulator Spring
- Servo Release Check Valve

Valve Body Parts

- Forward Accumulator Kit
- 1-2 Accumulator Valve Shim
- TCC Pressure Limiter:
 - TCC Valve
 - TCC Spring
- Checkballs (8)
- Separator Plate Plugs Not Shown
- Twist Drills Not Shown

Accumulator Parts

- 1-2 Pinless Accumulator Piston Kit
- 1-2 Accumulator Inner Spring
- 1-2 Accumulator Outer Spring
- 1-2 Accumulator Waved Spring
- Accumulator Housing Spacer

The parts listed here may be protected by one of these patent numbers: 6,619,323 & 6,899,211.

NOTE: For more radical applications and even greater levels of performance, combine the Performance Pack with the Sonnax 2nd Gear Super Hold Servo Kit **77911-03K** and 4th Gear Super Hold Dual Servo Kits **77911-03K** & Kit **77767K**.

4L60-E, 4L65-E, 4L70-E

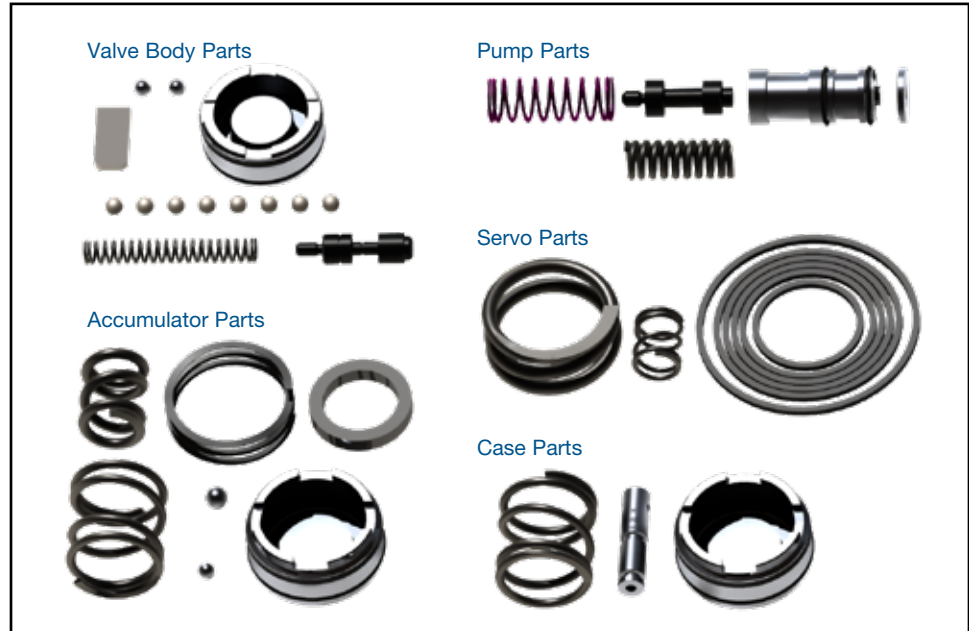

Before You Begin

1996-1998 4L60-E applications with two solenoids on front of valve body are programmed for pulse-width modulated (PWM) torque converter clutch (TCC) control. 1998-later applications are programmed for “partial slip” of the TCC under light load conditions (EC3). Both applications have clutch friction material specially suited to partial slip conditions. High performance converters may be built with on/off friction material that should not be allowed to slip. For converters built with on/off material, it is necessary to disable the partial slip function of the transmission by reprogramming the computer or modifying the transmission with the Sonnax TCC pressure limiter option.

The Sonnax TCC pressure limiter is a calibrated pressure-control spring that allows on/off converter operation without causing converter pressures to go too high. Other common modifications to the TCC regulator bore in the valve body which block the valve or add a different valve/spring combination cause line pressure to apply the converter clutch at double normal converter pressures. This leads to extra force on the engine crankshaft thrust bearing and causes TCC piston flexing that – over time – leads to broken rivets and converter failure, as well as trouble codes.

The TCC pressure limiter modification in this kit is the **ONLY** available modification that both eliminates PWM/EC3 operation **AND** regulates converter pressure to acceptable levels.

If you desire to keep OE PWM/EC3 operation, **DO NOT** install Sonnax pressure limiter. Ensure correct PWM/EC3 friction material is used in your converter.

With the pressure limiter spring and Sonnax TCC valve from the Performance Pack or the Sonnax sleeve kit **77754-04K***, TCC apply pressure will be limited to about 100 psi. With the pressure limiter spring and Sonnax sleeve kit **77754-03K***, TCC apply pressure will be limited to about 120 psi.

*Kits sold separately.

Valve Body Parts

1. Determine what style TCC valve is in your valve body by comparing valve lineup (Figure 1).

- **For '93-'94 Non-PWM:** Original valve can be reused, there is no need to install Sonnax TCC Pressure Limiter unless bore is worn. If bore is worn, it must be reamed and Sonnax sleeve kit 77754-03K* installed.
 - **For all '95-Later:** Follow inspection and installation steps.
 - **'96-Later GM Remanufactured "SERV" with Oversized TCC Regulator:** Reference Sonnax guidelines for tool 77754-SERV. See Figure 1 to identify a SERV valve body.
2. Inspect TCC regulator valve bore for wear (Figure 2). Vacuum testing is the preferred and most reliable testing method.
3. If the bore is okay, proceed to Step 2 for pressure limiter installation instructions. If the bore is excessively worn, it must be reamed and Sonnax sleeve kit 77754-04K* or 77754-03K* installed.

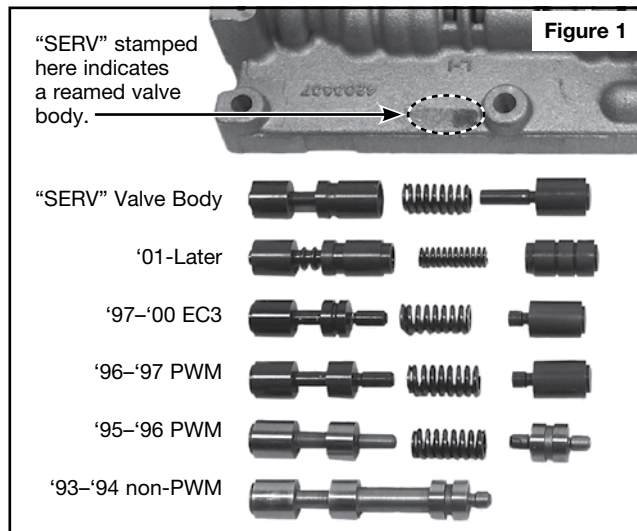

2. Pressure Limiter Installation



CAUTION: Before installing pressure limiter, see "Before You Begin" section on page one.

- Locate the PWM hole in the separator plate. Bore this orifice with a 1/16" drill bit, then lightly chamfer both sides of the plate. Install Sonnax small aluminum plug andpeen in place with a hammer (Figure 3).
- For un-reamed OE bore, install Sonnax TCC limiter spring, then the Sonnax regulator valve included in this kit and OE end plug (Figure 4).
 - For bore reamed to accept Sonnax regulator valve/sleeve kit 77754-04K* or 77754-03K*, install Sonnax TCC limiter spring, then the regulator valve/sleeve kit 77754-04K* or 77754-03K* and discard the regulator valve included in this kit (Figure 5).



NOTE: Do NOT install inner isolator valve with the pressure limiter spring.

*Kits sold separately.

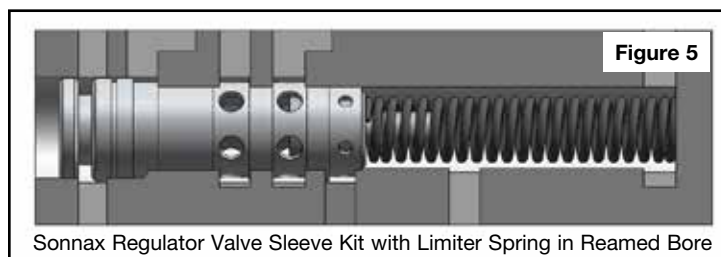
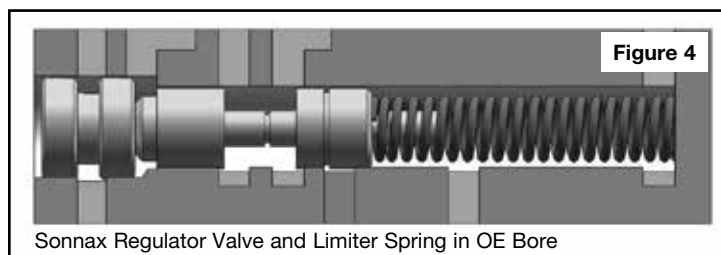
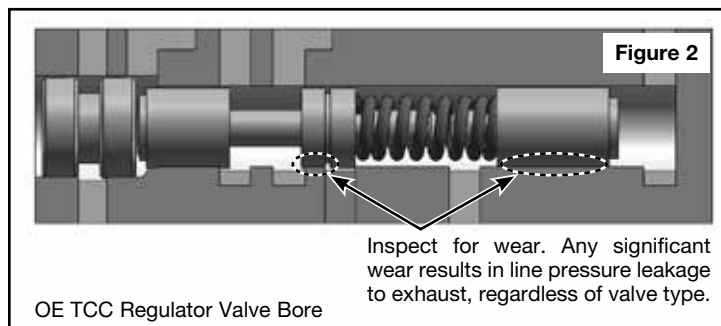
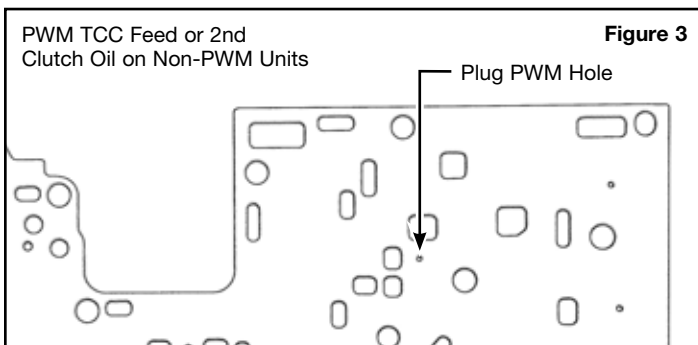

3. Pinless Forward Accumulator Installation

- Remove OE piston, pin and seal and discard (do not reuse the OE D-ring seal).
- Plug the pin bore in bottom of accumulator bore by installing two .238" dia. Sonnax steel balls (Figure 6). Lightly stake pin bore after driving balls in.
- Install Sonnax D-ring seal at domed end of piston. Install Sonnax PTFE seal at open end of piston.
- Install Sonnax piston and OE spring. Secure with OE cover and screws (Figure 6).

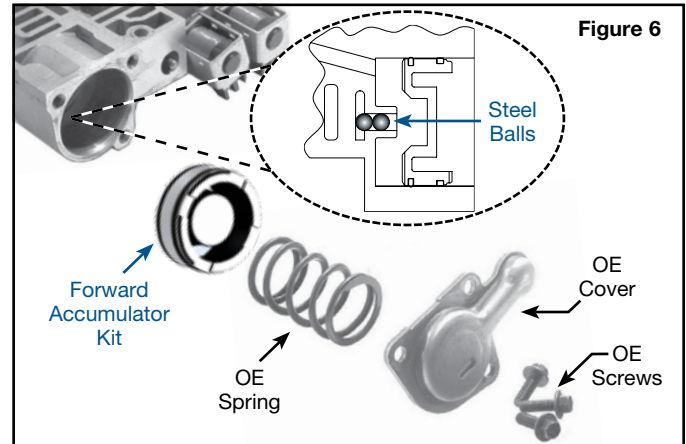

4. Separator Plate

- Drill the plate as indicated to the following specifications (Figure 7):
 - Hole "A" (3-2 shift) use drill .093" #42.
 - Hole "B" (2nd clutch) use drill .093" #42.
 - Hole "C" (3rd clutch) use drill .093" #42.
 - Hole "D" (4th clutch) use drill .093" #42.
 - Hole "E" (AFL balance oil) use drill .052" #55.
- Install eight Sonnax plastic checkballs in original locations.

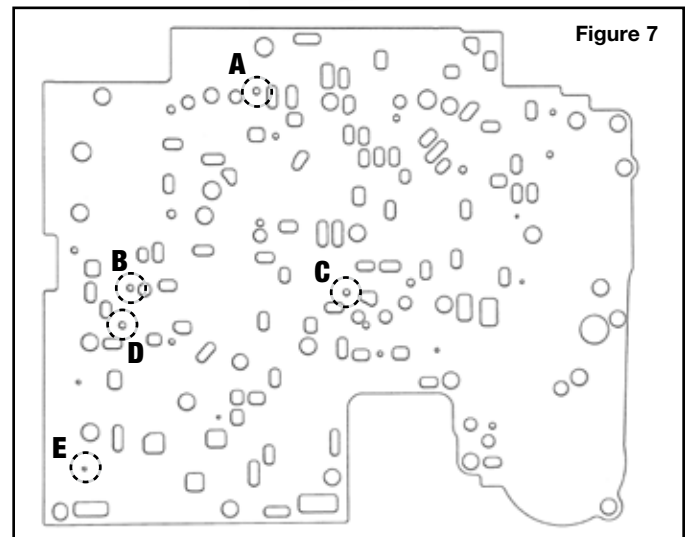

5. 1-2 Accumulator Valve Shim Installation

- Reuse OE accumulator valve spring.
- Install shim into sleeve pocket, beveled side down. This can be done by removing the accumulator valve or by simply inserting the shim between the spring and the end of the bore using a feeler gauge as an installation tool (Figure 8).

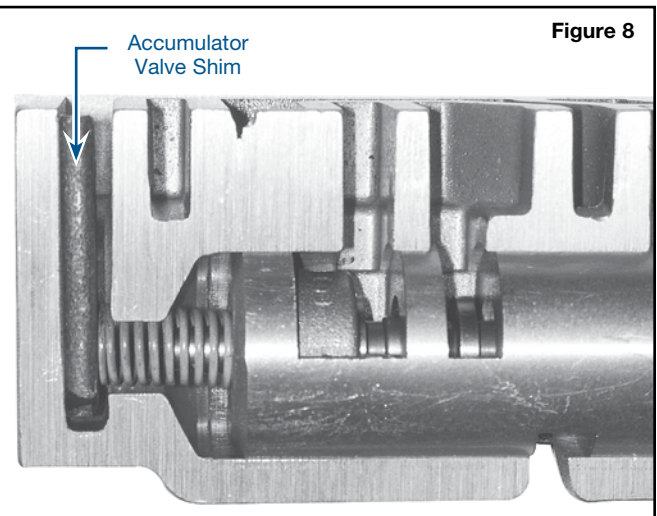
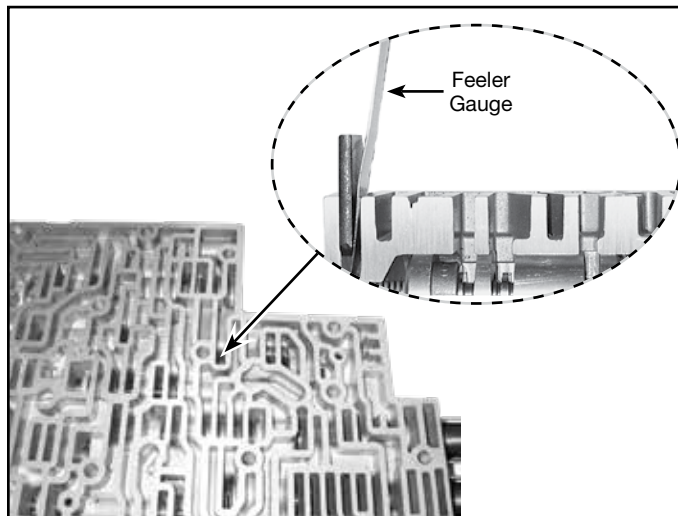

Accumulator Parts

6. Pinless 1-2 Accumulator Installation



NOTE: Do not use this accumulator kit with '93 housings. '01-Later housings need to have the spacer installed, '94-'00 Housings do not need the spacer (**Figure 9**).

- Remove piston pin from the 1-2 accumulator housing.
- OE pin diameter varies. Plug pin hole by driving one appropriately sized Sonnax steel ball (.236" or .312" dia.) into hole. Discard unused ball.
- Stake ball in place.
- Install rubber D-ring toward piston dome. Install PTFE seal toward open end.
- For '01-later housings, install Sonnax accumulator housing spacer into accumulator body.
- Install Sonnax inner and outer springs into accumulator body.
- Set piston pocket opening onto spring, dome toward plate.
- Install Sonnax waved spring.

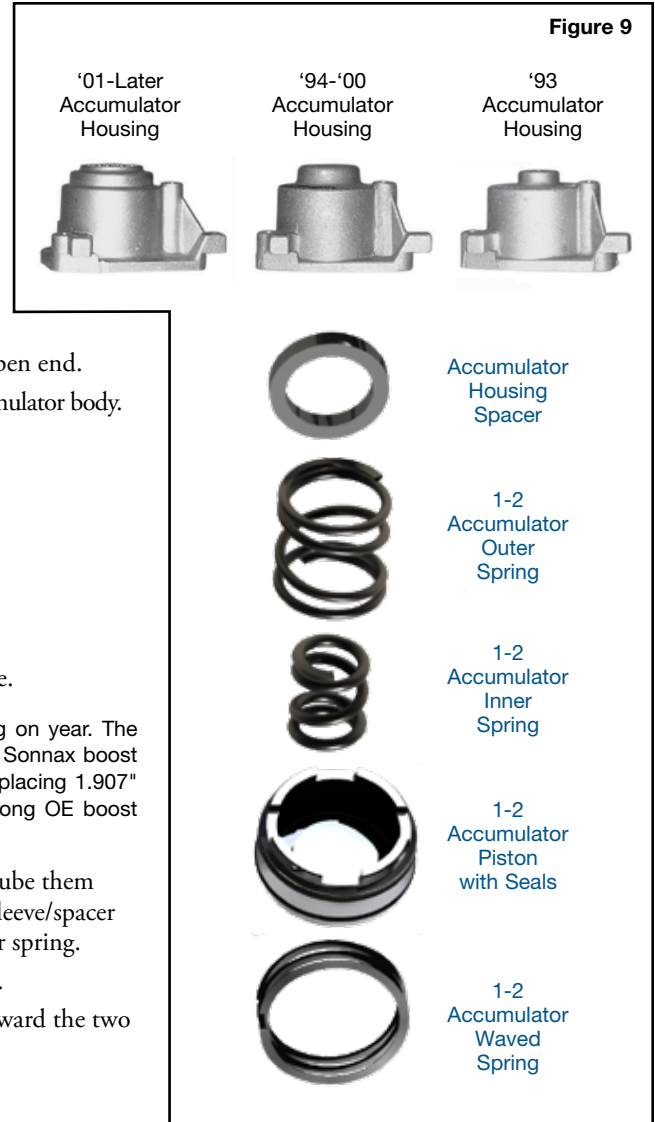

Pump Parts

7. PR Boost Valve & Spring Installation

- Remove OE boost sleeve and springs. Save OE bumper spring for reuse.



WARNING: The OE boost valve sleeve comes in two lengths, depending on year. The 1994-2004 boost sleeve is longer (1.907") and should be replaced with the Sonnax boost sleeve AND included Sonnax spacer. If spacer is not installed when replacing 1.907" sleeves, transmission failure will result! For 2005-later applications with 1.810" long OE boost sleeve, do NOT install Sonnax spacer.

- After placing the two O-rings into the grooves on the boost sleeve, pre-lube them and roll sleeve over bench to resize the O-ring. Assemble correct boost sleeve/spacer combination, OE bumper spring and Sonnax elevated pressure regulator spring.
- Insert Sonnax valve into sleeve with nubbed end facing out (**Figure 10**).
- Carefully insert sleeve assembly into pump body with the open end toward the two springs, just deep enough to reinstall OE retainer clip.

8. Pump Slide Spring Installation

Remove both OE pump slide springs from pump housing and replace with Sonnax spring (**Figure 11**).

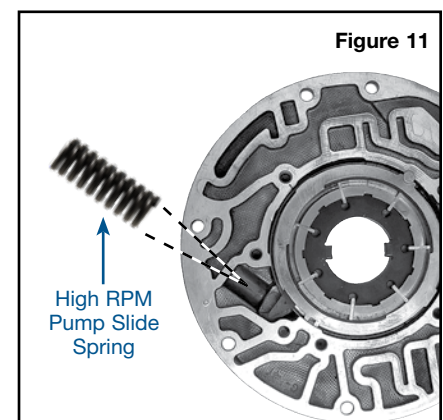
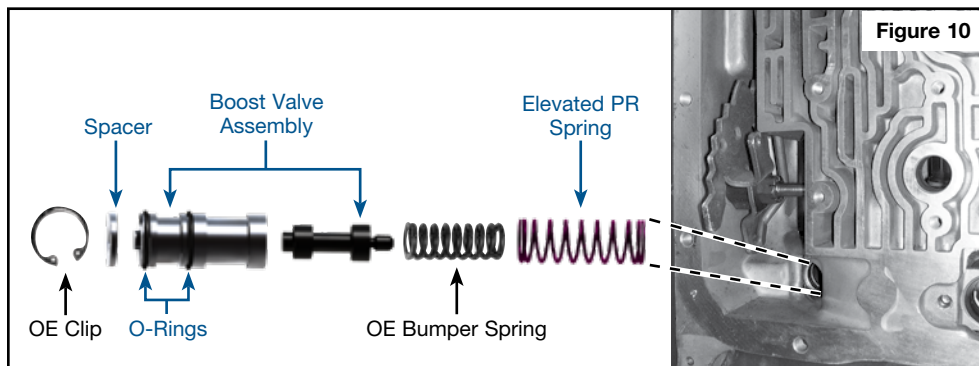

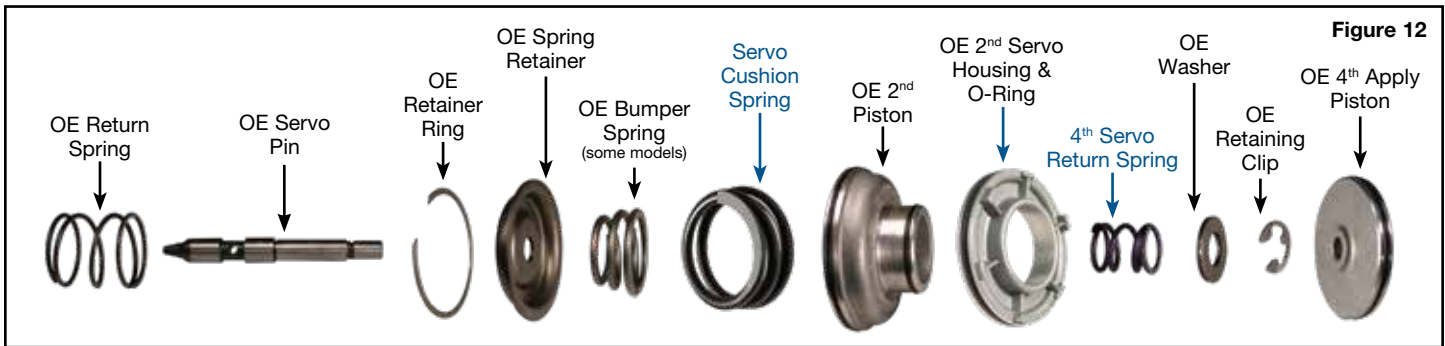

Servo Parts

9. Servo Installation

- Remove OE servo cushion spring and replace with Sonnax servo cushion spring (**Figure 12**).
- Reinstall the conical OE bumper spring if used in your application.
- Replace OE 4th servo return spring under the washer and C-clip with Sonnax 4th servo return spring.
- Install rubber D-rings onto servos. Ensure seals are not twisted in groove.

Case Parts

10. Servo Release Check Valve Installation

The bore in the case is not a critical diameter for OE manufacturing purposes, so some variations in the fit of the check valve are possible. The O-ring ensures a positive seal in cases with larger bores. The check valve is installed between the OE checkball capsule and the separator plate. The check valve DOES NOT replace the OE checkball capsule (**Figure 13**).

- Install the check valve, tapered end first, into the case. If resistance is felt, tap the check valve in until flush or just below flush with the case. If it slides all the way in without resistance, remove and reinstall with Sonnax O-ring (**Figure 14**).
- Run a straight edge over the case to verify the check valve is not sticking up above the case gasket surface.

11. Pinless 3-4 Accumulator Installation

- Remove accumulator pin.



NOTE: Pin bore is blind in this location, so there is no need to plug with any checkball.

- Install D-ring toward dome with PTFE seal toward open end. Install dome toward case (**Figure 15**).
- Install Sonnax 3-4 accumulator spring.

