



TOYOTA/LEXUS U140E, U140F, U240E, U241E ZIP KIT®

PART NUMBER U140E-U241E-ZIP

QUICK GUIDE

Parts are labeled here in order of installation. See other side of sheet for details on kit contents.

INSTALLATION DIAGRAM

Upper Valve Body

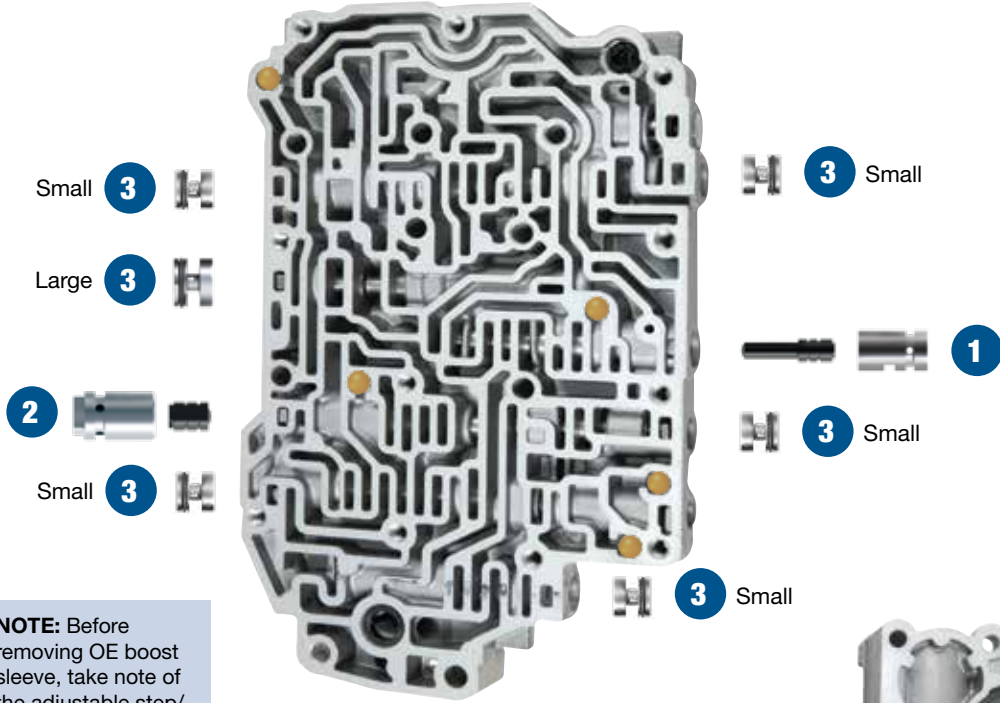

Install with open end out.

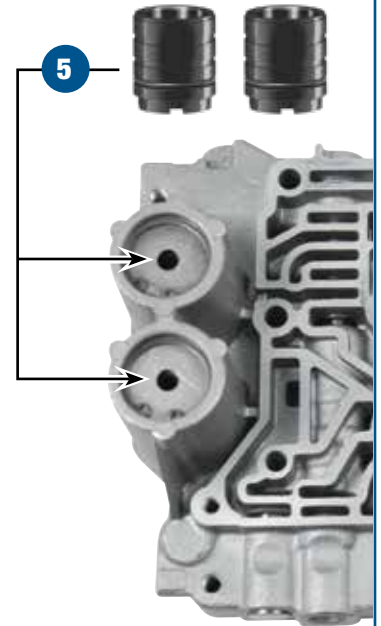

NOTE: Before removing OE boost sleeve, take note of the adjustable step/pin location and ensure the Sonnax sleeve is installed at the same height/location. Failure to do so will result in incorrect line rise.



Cutaway shows a side view of lower valve body with Sonnax boost valve kit installed.

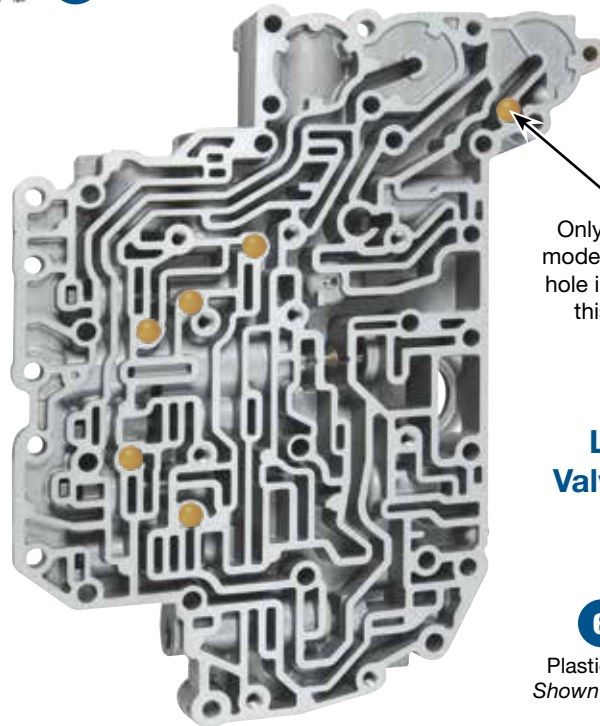
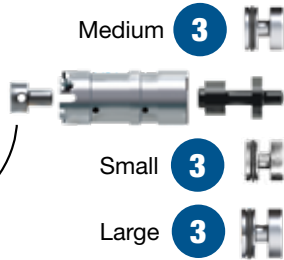

Only use here in models that have a hole in the plate at this location.

Lower Valve Body

6 Plastic Checkball
Shown in 11 places.

In addition to general rebuilding tips and technical information, the technical booklet included in this kit contains vacuum testing and additional repair options for higher mileage units or for repairing specific complaints which are beyond the scope of this kit.

Kit Contents & Installation Steps

Step 1 Replace OE Clutch Apply Control Sleeve & Plunger Valve

Packaging Pocket 1

- Plunger Valve
- Plunger Sleeve

Step 2 Replace OE Lockup Control Sleeve & Plunger Valve



NOTE: Reuse OE spring if applicable.

Packaging Pocket 2

- Plunger Valve
- Plunger Sleeve

Step 3 Replace OE End Plugs



NOTE: Install all end plugs with the O-ring outboard. Place O-ring into end plug groove. Lubricate with Sonnax Slippery Stick **O-LUBE** and roll on bench to size.

Packaging Pocket 3

- Small End Plugs (6)
- Small O-Rings (9) 3 Extra

Packaging Pocket 4

- Medium End Plug
- Medium O-Rings (2) 1 Extra

Packaging Pocket 5

- Large End Plugs (2)
- Large O-Rings (3) 1 Extra

Step 4 Replace OE Boost Sleeve & Valve

Packaging Pocket 6

- Boost Valve
- Boost Sleeve
- Boost Plug

Step 5 Replace OE Accumulator Pistons



NOTE: Place O-ring into deepest piston groove. Lubricate with Sonnax Slippery Stick **O-LUBE** and roll on bench to size. Install into casting bore with the O-Ring inboard.

Packaging Pocket 7

Accumulator Piston

Packaging Pocket 8

Accumulator Piston

Packaging Pocket 9

O-Rings (3)

1 Extra

Step 6 Replace OE Checkballs

Packaging Pocket 10

Plastic Checkballs (11)



TOYOTA/LEXUS U140E, U140F, U240E, U241E ZIP KIT®

PART NUMBER **U140E-U241E-ZIP**

INSTALLATION & TESTING BOOKLET

Torque Specifications	
Pan Filter to Valve Body 96 in-lb	Oil Pan to Transaxle 72 in-lb
Component Pack Clearance	
Forward (C1) Clutch U140E/F: 4-Cyl .069-.082" U140E/F: V6 .082-.095" U240/241E: .056-.069"	Low & Reverse (B2) Brake U140E/F: 4-Cyl .040-.048" U140E/F: V6 .043-.051" U240/241E: .043-.049"
2nd (B1) Brake U140E/F: .024-.036" U240E: .024-.029" U241E: .024-.036"	Direct (C2) Input U140E/F: .024-.033" U240/241E: .024-.029"
Underdrive (C3) Clutch U140E/F: .059-.075" U240E/241E: .058-.067"	Underdrive (B3) Brake U140E/F: .071-.087" U240/241E: .074-.082"
End Play	
Input Shaft U140E/F: .010-.049" U240E/241E: .011-.049"	Underdrive Unit U140E/F: .020-.039" U240E/241E: .008-.027"
Direct Clutch Assembly U140E/F: .008-.037" U240E/241E: .008-.035"	
Fluid	
Toyota Type T-IV	

Electronic Cautions

Resetting Shift Adapts

The ECM (engine control module) has memorized values which must be relearned after transmission repair. Use a scan tool (OE factory tool recommended) to reset the ECM.

Post-Adapt Road Test

After resetting the ECM, a road test is required. Start the engine and warm it to normal operating temperature. Perform a thorough road test with multiple accelerations from a stop until proper shifting is obtained.

TSB TC002-06

Toyota published a Technical Service Bulletin regarding computer hardware problems in 2001-2003 RAV4 vehicles. Resetting the ECM will not eliminate shifting complaints for this unit. A new ECM will be required.

Solenoids

Solenoids should be cleaned to remove debris that results in sticking and malfunction.

Toyota/Lexus U140E/F, U240E, U241E Clutch Application Chart

Gear Range	C1	C2	C3	B1	B2	B3	F1	F2
Park						ON		
Reverse		ON			ON	ON		
Neutral						ON		
D-1st Gear	ON					ON	ON	ON
D-2nd Gear	ON			ON		ON		ON
D-3rd Gear	ON	ON				ON		ON
D-Overdrive	ON	ON	ON					
2-1st Gear	ON					ON	ON	ON
2-2nd Gear	ON			ON	ON	ON		ON
Low-1st Gear	ON				ON	ON	ON	ON

Toyota/Lexus U140E/F, U240E, U241E Solenoid Function & Apply Chart

Gear	SL1 Controls B1 Brake	SL2 Controls C2 Clutch	S4 Controls 3-4 Shift
1st	ON	ON	Off
2nd	Off	ON	Off
3rd		Off	Off
4th		Off	ON

SLT: Controls line pressure.

DSL: Controls lockup clutch.

N-D ENGAGEMENT: 3rd gear is commanded during the engagement, then 1st after the engagement is complete.

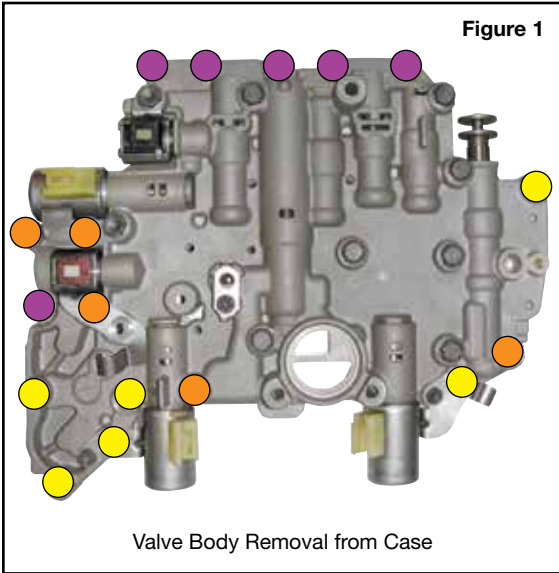

Zip Kit Instructions

1. Valve Body Removal from Case

NOTE: See color chart for bolt lengths.

Remove the 17 bolts indicated (**Figure 1**).

2. Valve Body Disassembly: Step 1

NOTE: See **Figure 2** and **3** for bolt locations.

The solenoids have differing resistance amounts (**Figure 2**). Ensure each of the solenoids are put back in their correct location.

a. Remove the five solenoids and bolts shown in **Figure 2**.

NOTE: Reference **Figure 3** for steps b through e.

b. Remove the eight upper valve body bolts, **#1** and **#2**.

c. Remove the seven upper valve body cover bolts, **#3** and **#4**.

d. Remove bolt **#5**, bracket and checkball.

e. Remove checkball, location **A**.

Bolt Color Code		Bolt Length
Red		10mm
Green		12mm
Blue		14mm
Purple		25mm
White		30mm
Yellow		41mm
Orange		45mm

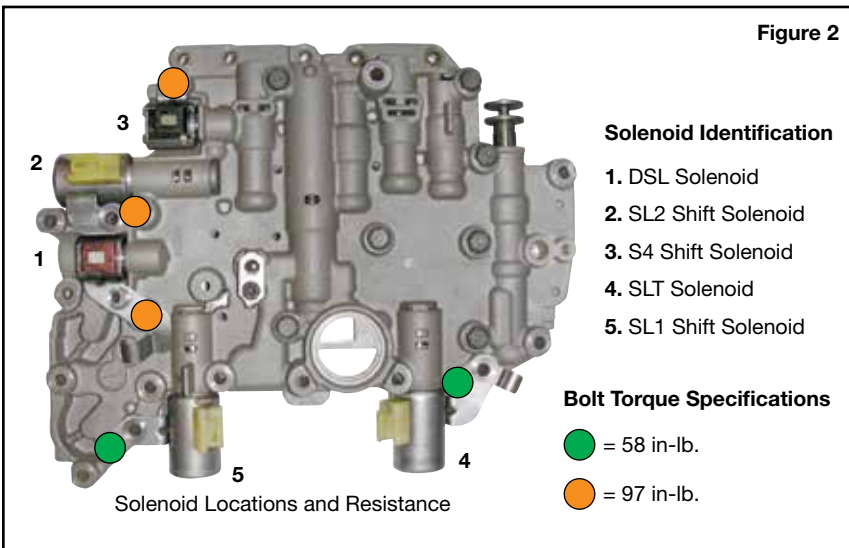

Solenoid Resistance Chart

Solenoid	U140E	U140F	U240E	U241F
SL1	5.1–5.5 ohms	5.0–5.6 ohms	5.0–5.6 ohms	5.0–5.6 ohms
SL2	5.1–5.5 ohms	5.1–5.5 ohms	5.1–5.5 ohms	5.1–5.5 ohms
S4	11–15 ohms	11–15 ohms	11–15 ohms	11–15 ohms
DSL	11–15 ohms	11–13 ohms	11–13 ohms	11–13 ohms
SLT	5.0–5.6 ohms	5.1–5.5 ohms	5.1–5.5 ohms	5.1–5.5 ohms

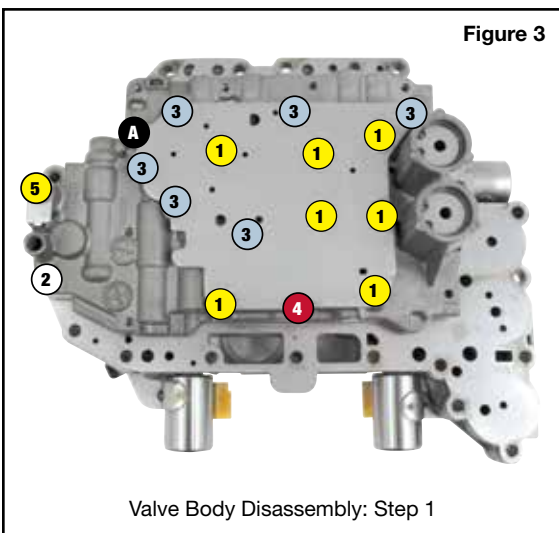

3. Valve Body Disassembly: Step 2

NOTE: See **Figure 4** for bolt locations.

- Remove the seven lower valve body bolts shown.
- Hold separator plate against lower valve body. Lift off of upper valve body and lay on bench with separator plate side up.
- Remove separator plate from lower valve body. Note the location of all the checkballs and retainers. Verification on page 8 in booklet.

4. Installation

Install Zip Kit parts as shown on diagram of separate quick guide sheet included in this Zip Kit.

- When installing the lockup control plunger valve and sleeve kit in Step 2, reuse the OE spring in between the new valve and sleeve if applicable.
- The Sonnax O-ringed end plugs in Step 3 must be installed with the O-ring outboard.

5. Valve Body Assembly: Step 1

NOTE: See **Figure 4** for bolt locations.

- Loosely install the seven bolts.
- Torque all bolts to 97 in-lb.

6. Valve Body Assembly: Step 2

NOTE: See **Figure 5** for bolt locations and torque specifications.

- Reinstall checkball, location **A**.
- Install checkball and bracket, then loosely install bolt **#1**.
- Loosely install the seven upper valve body cover bolts, **#2** and **#3**.
- Loosely install the eight upper valve body bolts **#4** and **#5**.
- Torque all bolts in previous steps according to specs in **Figure 5**.
- Install the five solenoids and bolts shown in **Figure 2** and torque per spec indicated.

7. Valve Body Reinstallation to Case

NOTE: See **Figure 6** for bolt locations.

- Loosely install all 17 bolts. Reference bolt color and length chart on previous page.
- Torque all bolts to 8 ft-lb.

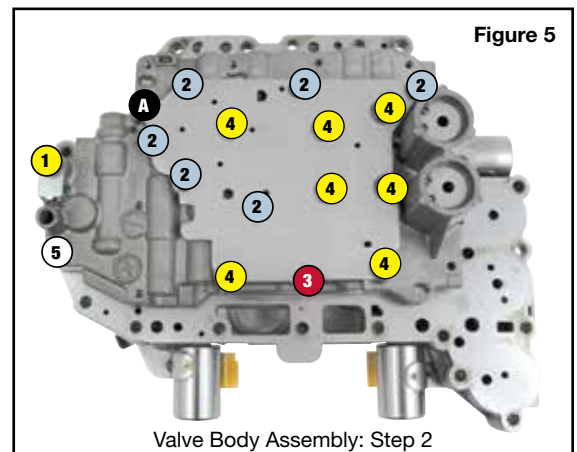
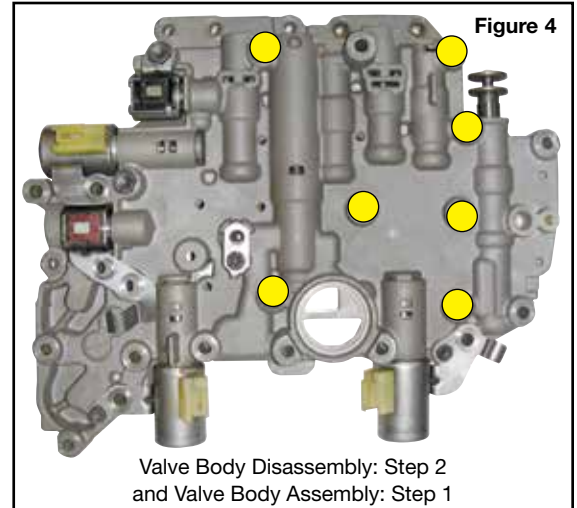

Bolt ID & Color Code	Installation Torque Specs
Bolt #1 ●	58 in-lb
Bolt #2 ●	58 in-lb
Bolt #3 ●	58 in-lb
Bolt #4 ●	97 in-lb
Bolt #5 ●	97 in-lb

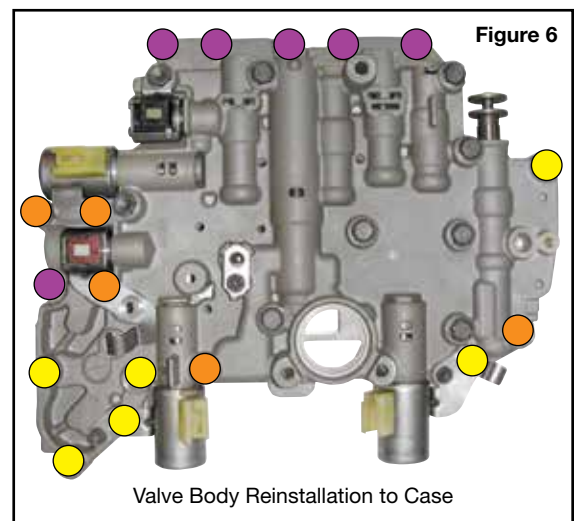

Critical Wear Areas & Vacuum Test Locations

NOTE: OE valves are shown in rest position and should be tested in rest position unless otherwise indicated. Test locations are pointed to with an arrow. Springs are not shown for visual clarity. Low vacuum reading indicates wear and Sonnax parts noted for replacement.

Upper Valve Body – Bottom Side • U241E Shown Here

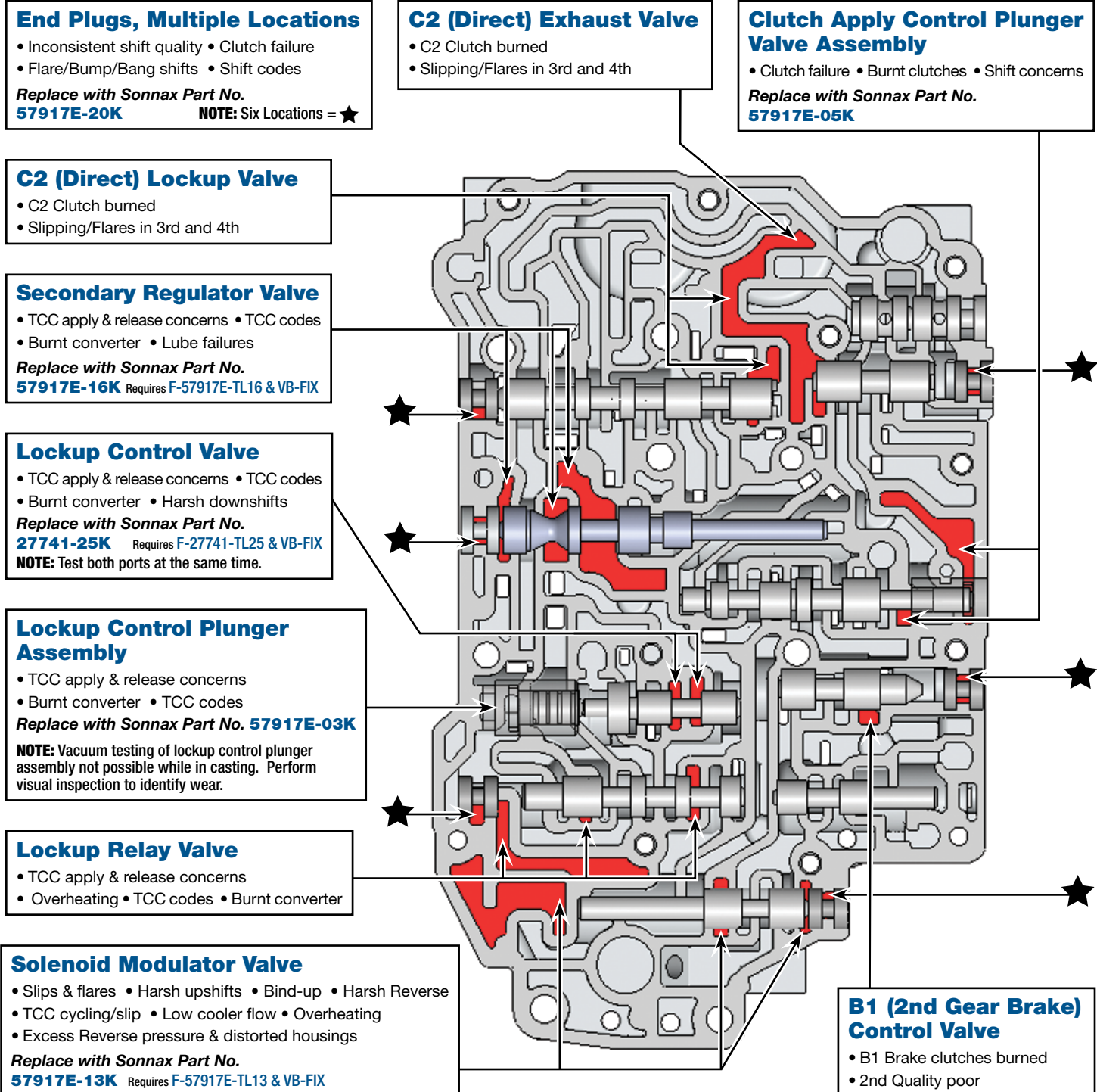

Part numbers with an asterisk () are included in this Zip Kit. Other part numbers are available separately.



For specific vacuum test information, refer to individual part instructions included in kits and available at www.sonnax.com.

Upper Valve Body – Top Side • U241E Shown Here

C2 (Direct) Accumulator Piston

- Delayed engagement • Flare shifts
- Forward slip • Burnt clutches

Replace with Sonnax Part No.
57917E-19K

B1 (2nd Gear) Accumulator Piston

- Delayed engagement • Flare shifts
- Forward slip • Burnt clutches

Replace with Sonnax Part No.
57917E-19K

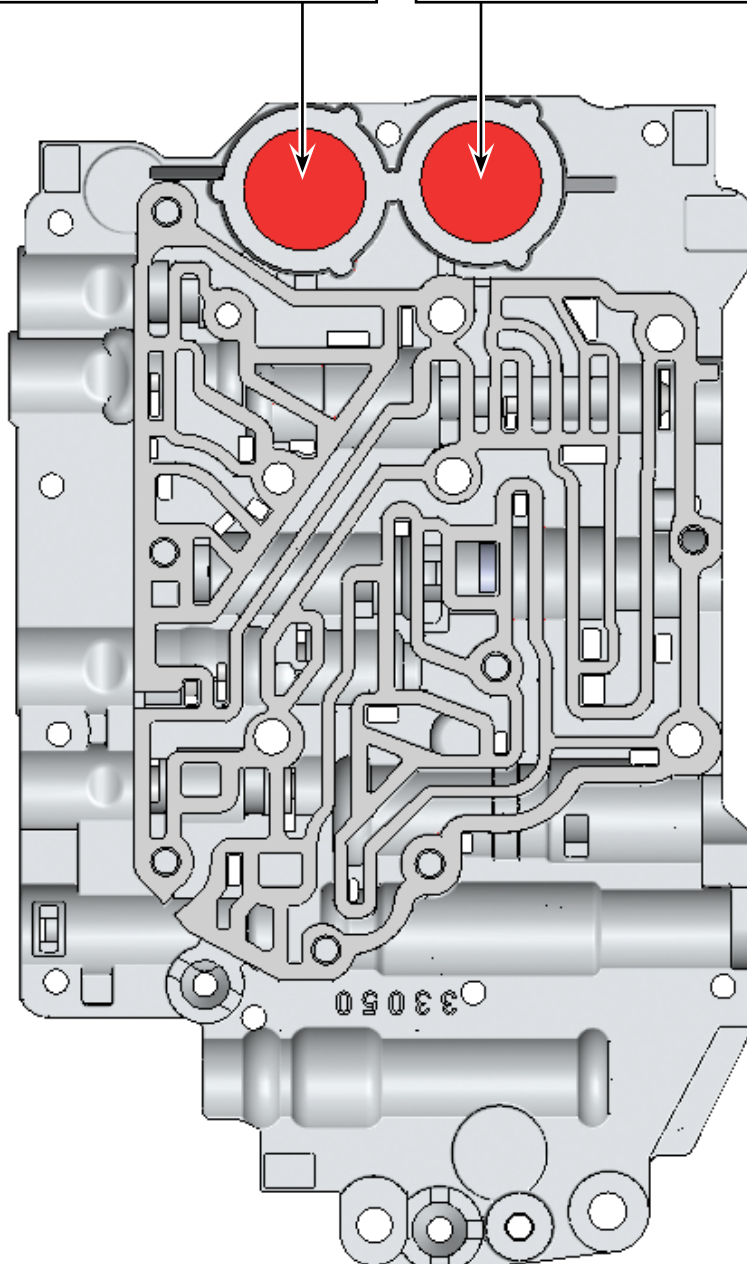

Items without part numbers are valid vacuum test locations for indicated drivability complaints, but do not have corresponding Sonnax parts due to low percentage of bore wear.

Critical Wear Areas & Vacuum Test Locations

NOTE: OE valves are shown in rest position and should be tested in rest position unless otherwise indicated. Test locations are pointed to with an arrow. Springs are not shown for visual clarity. Low vacuum reading indicates wear and Sonnax parts noted for replacement.

Lower Valve Body – Bottom Side • U241E Shown Here

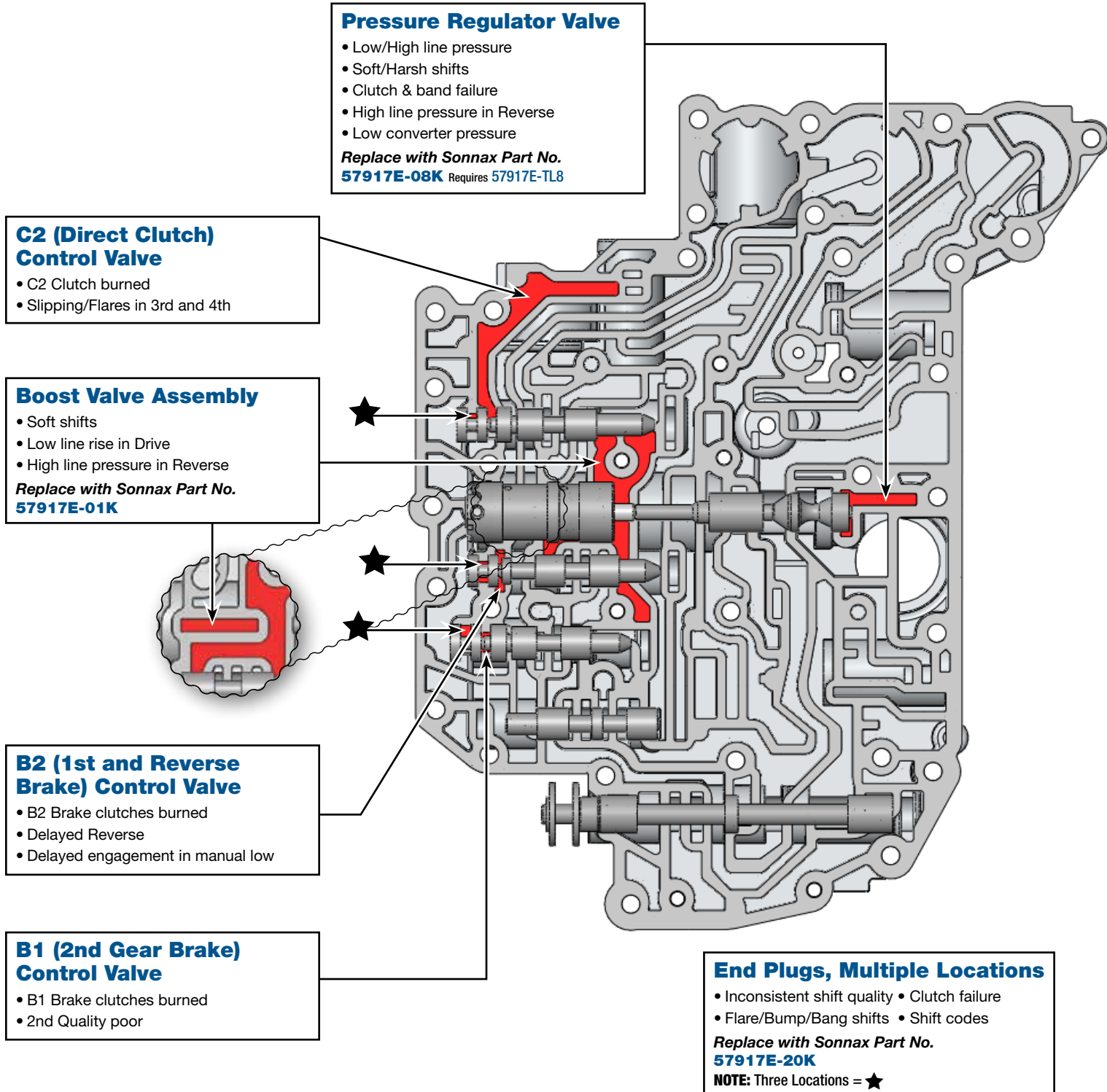

Part numbers with an asterisk () are included in this Zip Kit. Other part numbers are available separately.

OE Exploded View

Upper & Lower Valve Body • U241E Shown Here

Upper Valve Body Descriptions

I.D No.	Description
101	C2 Lockup Valve
102	Secondary Regulator Valve
103	Lockup Control Valve
104	Lockup Relay Valve
105	Solenoid Modulator Valve
106	B3 Orifice Control Valve
107	B1 Lockup Valve
108	Clutch Apply Control Valve
109	C2 Exhaust Valve
110	Three-Way Check Valve

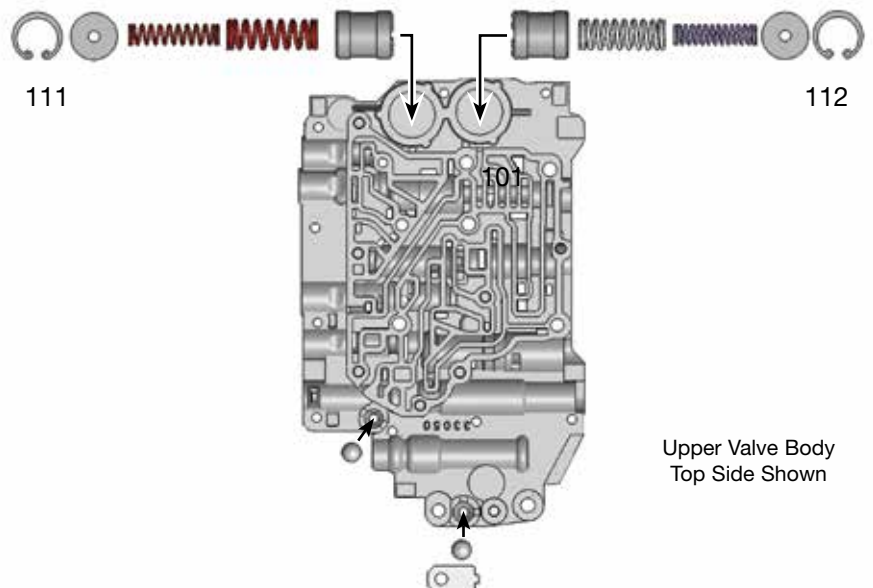
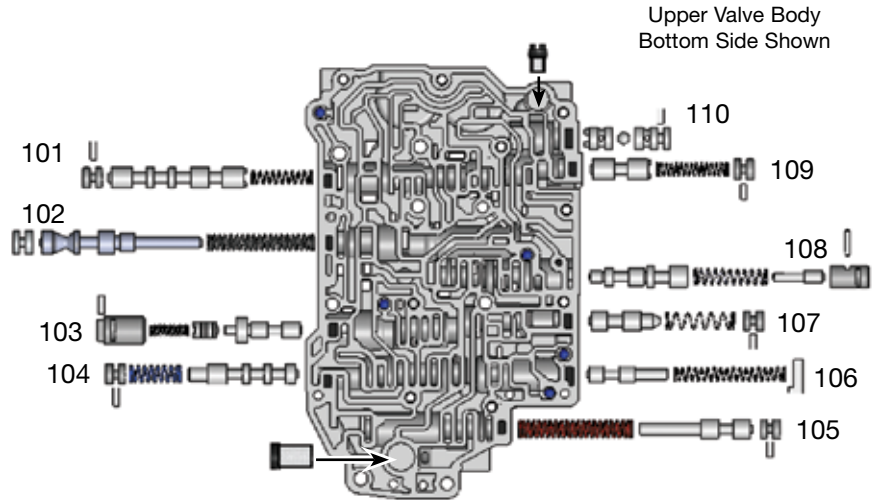

Upper Valve Body Descriptions

I.D. No.	Description
111	C2 Accumulator Piston
112	B1 Accumulator Piston

OE Exploded View

Upper & Lower Valve Body • U241E Shown Here

Lower Valve Body Descriptions

I.D No.	Description
201	C2 Control Valve
202	Main Regulator Valve
203	B2 Control Valve
204	B1 Control Valve
205	3-4 Shift Valve
206	Manual Valve

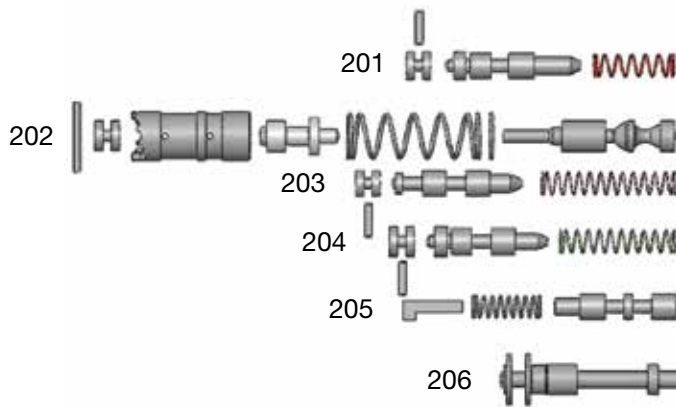

*Checkball is not used in all units.
Only use in models that have a
corresponding hole in the
separator plate at this location.*

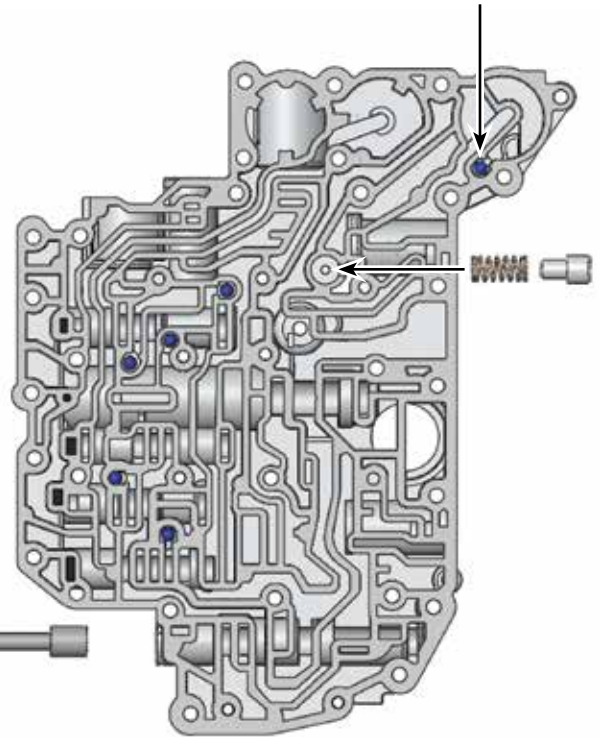

Lower Valve Body
Bottom Side Shown

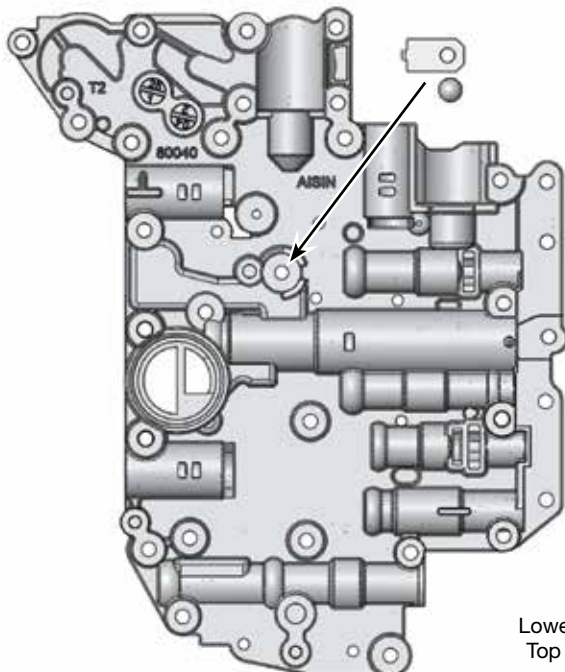

Lower Valve Body
Top Side Shown