

**Actuator Feed  
Limit Valve Kit**



**Part No.**  
**34200-16K**

- Valve
- Sleeve
- Long Spring
- Short Spring
- Retaining Clip

Patent No. 6,634,377

**Tool Kit**

**Part No.**  
**77754-TL**

- Reamer
- Core Drill Bit                   4L80-E Only
- Reamer Jig                       4L60-E Only
- Reamer Jig                       4L80-E Only
- Drill Guide                       4L80-E Only
- Drill Bit                           .052" (not shown)

**NOTE:** This tool kit works for both 4L80-E and 4L60-E AFL valve repairs.

**GM 4L80-E, 4L85-E**

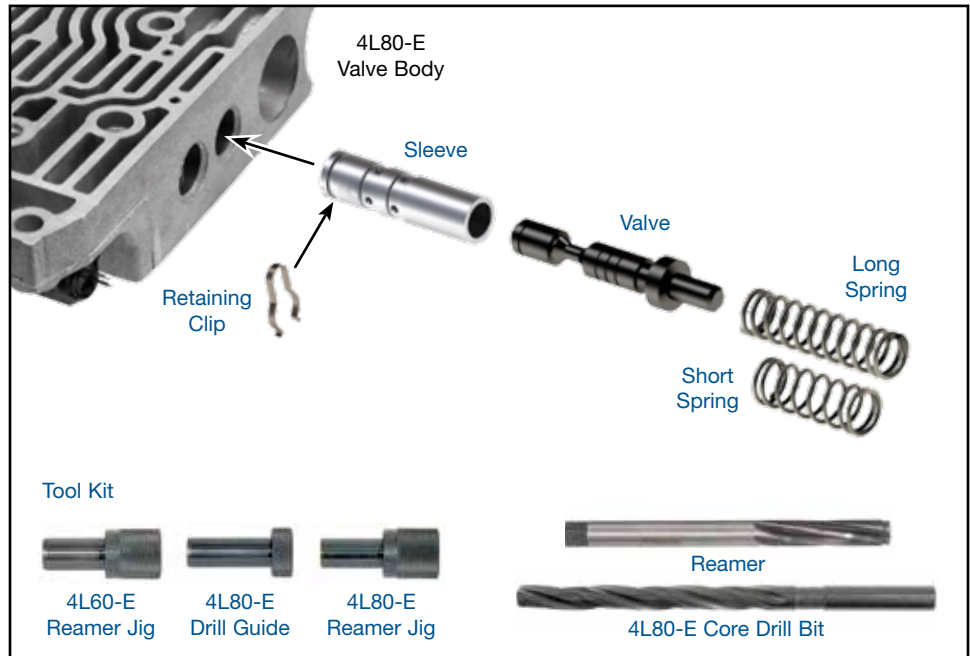

**1. Disassembly**

Remove OE AFL valve lineup. Set aside valve train, to be inspected after reaming.



**WARNING:** Do not discard any OE parts until correct lineup is identified in step 4, "Installation & Assembly".

**2. Drill AFL Bore (Must be done prior to reaming)**

- Clamp valve body to bench, circuits facing upward.
- Insert drill guide from Sonnax tool kit 77754-TL into bore and fill bore with cutting fluid (**Figure 1**).
- Using core drill bit from tool kit 77754-TL, drill bore at approximately 1000 RPM, until bit bottoms out. Take care not to force drill or let it "grab" while drilling.
- After drilling, prepare for reaming by thoroughly cleaning valve bore and body of debris.

**3. Reaming**

Ream AFL bore (for reaming instructions/reamer care, please visit [www.sonnax.com](http://www.sonnax.com)). Reaming tool kit 77754-TL is required for this operation.

**4. Installation & Assembly**

- Ensure valve bore and body are clean and clear of debris.
- Install Sonnax sleeve/valve assembly. Secure with Sonnax retaining clip.



### 4. Installation & Assembly (continued)

**NOTE:** Sleeve must fit bore with slight resistance. If sleeve slides in easily or rotates in bore, a tubing cutter may be used to raise a slight ridge around sleeve lands (**Figure 2**). Liquid sleeve retainer (such as Loctite® 609) is an alternative, used sparingly on inboard end of sleeve. Apply a surface prep/cleaner (such as Permatex® 24163) to the sleeve and bore, which speeds cure and insures retention. This will cure within 30 seconds, so quickly install the sleeve without the valve. After cure, install valve into sleeve.

c. Select correct Sonnax spring:

- c1. If 1st OE design AFL lineup was originally installed, use Sonnax short spring (**Figure 3**).
- c2. If 2nd OE design AFL lineup was originally installed, use Sonnax long spring (**Figure 4**).

d. Install correct Sonnax spring.

e. For OE 1st design lineup, reinstall OE spacer and retainer (**Figure 3**, same as c1 above).

f. For OE 2nd design lineup, reinstall OE retainer.

### 5. Separator Plate Modification

Enlarge indicated AFL balance orifice to .052" with Sonnax drill bit included in 77754-TL tool kit (**Figure 5**).

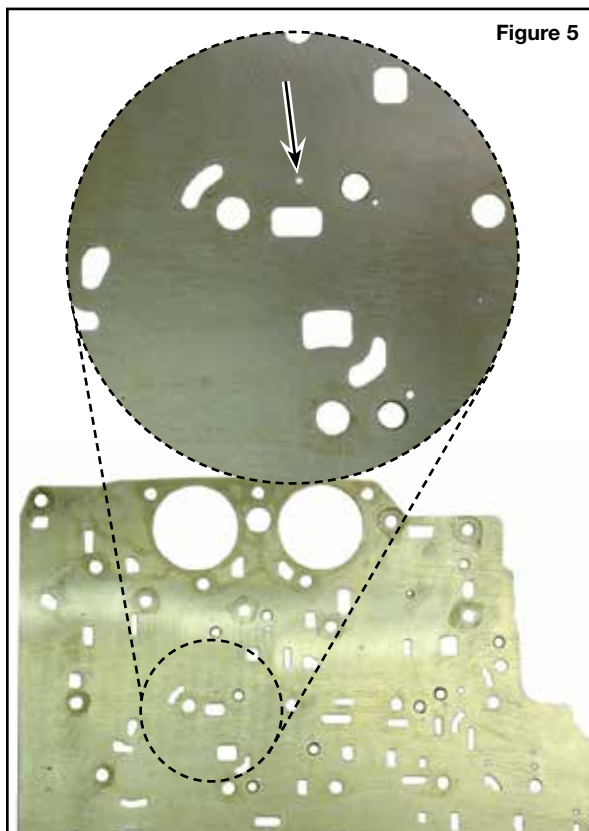

Figure 5

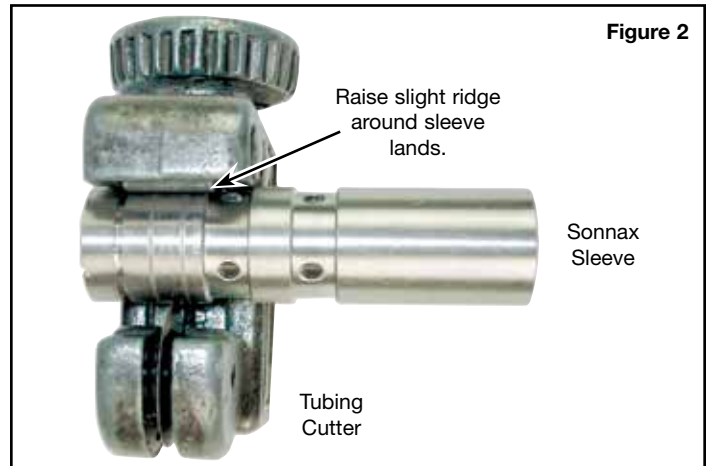

Figure 2

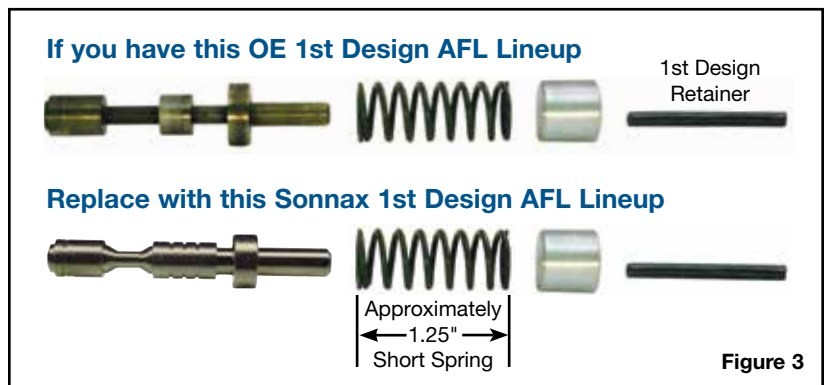

Figure 3

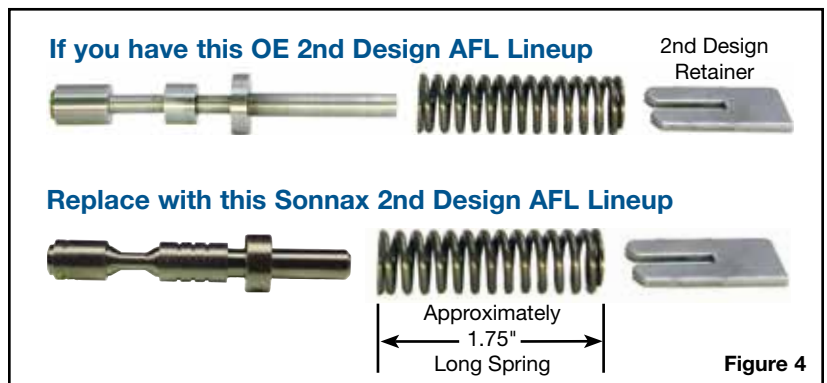

Figure 4

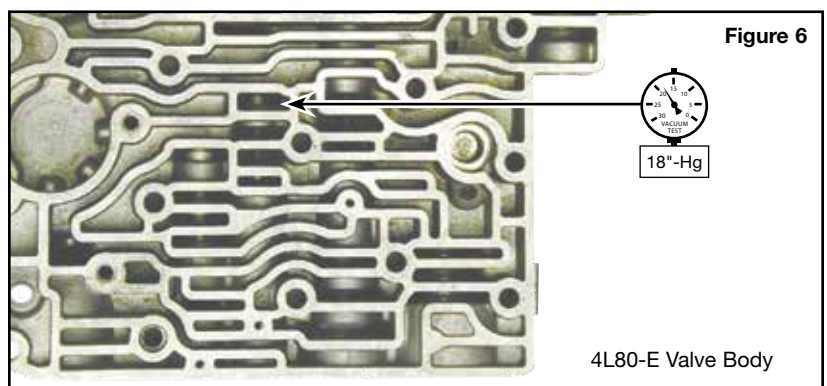

Figure 6

4L80-E Valve Body