

GM 200-4R, 4L60

TV Boost Valve Kit

Part No.

77917-01K

- Valve
- Sleeve
- O-Rings (2)

.500" Dia.

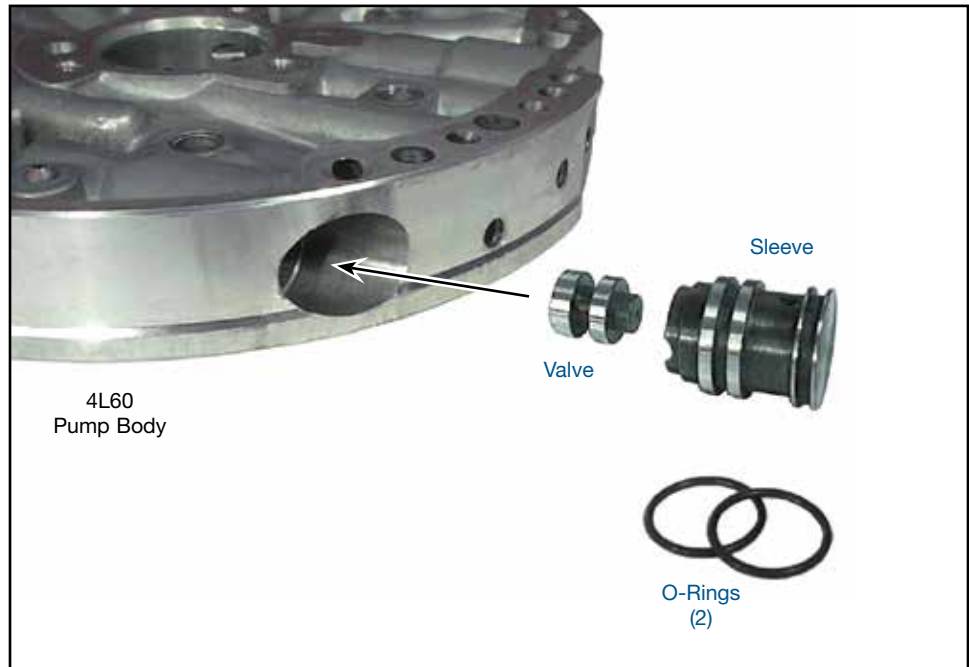

1. Disassembly

- Remove snap ring and save for reuse.
- Remove and discard OE boost sleeve and valve.

2. Installation & Assembly

- Install Sonnax O-rings into the grooves on the Sonnax boost sleeve.
- Install Sonnax valve into Sonnax sleeve with the nubbed end facing in.
- Lubricate the bore and throttle valve sleeve and carefully push the Sonnax assembly in just far enough to reinstall OE snap ring.

Sonnax Part No.	Sleeve Dia.	Performance Application
77917-01K	.423" dia.	Minimum line pressure for V8 applications
77917-471	.471" dia.	Higher line pressure for towing and off-road
77917-500	.500" dia.	Maximum line pressure & shift feel for high performance applications