

TCC Apply Valve Kit

Part No.
77805-K

- Valve
- PTFE Seal

NOTE: Upon removing the OE valve, lay it next to the Sonnax replacement and verify the spool locations match as indicated (**Figure 1**). Some early PWM pumps used steel TCC valves. Do not use steel and aluminum as the identification for replacement. Mismatching PWM & non-PWM valves will cause rapid converter failure.

WARNING: A common modification performed by rebuilders is to enlarge the TCC signal orifice in the pump to help ensure the TCC valve strokes completely during apply. DO NOT perform this modification when using the Sonnax valve; the TCC solenoid may become flooded by the increased oil flow and produce uncontrollable TCC apply.

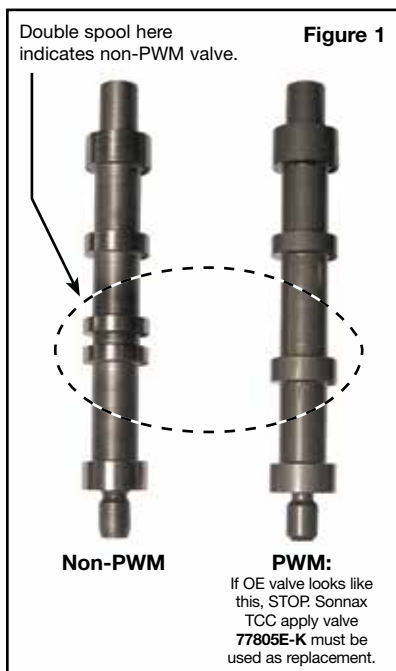

GM 200-4R, 4L60, 4L60-E Non-PWM

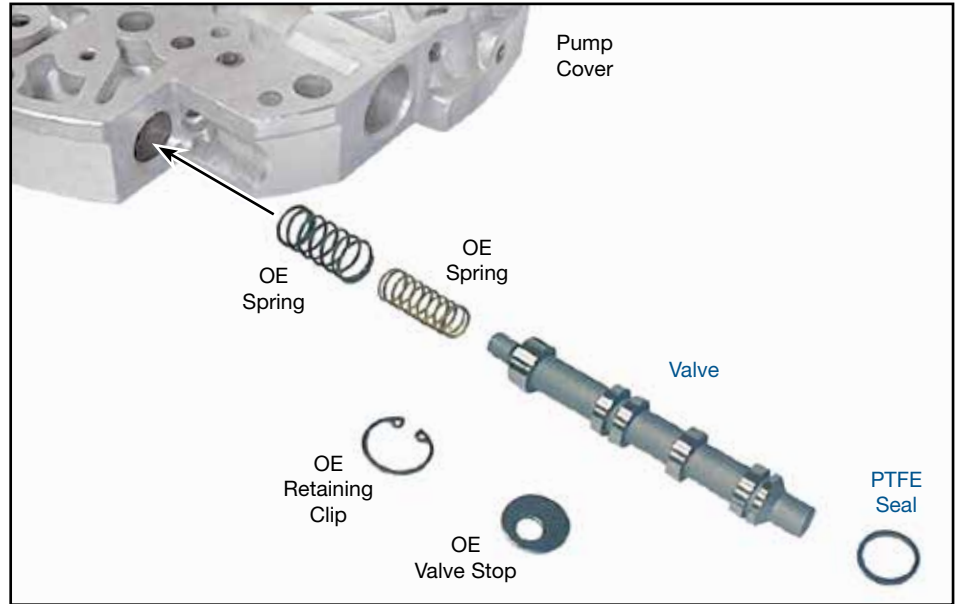

1. Disassembly

- Remove OE TCC apply valve train.
- Retain OE springs, retaining clip and valve stop for reuse.
- Discard OE valve.

- Insert OE springs and the Sonnax valve into bore, ensuring PTFE ring end of valve is outboard.
- Reinsert OE valve stop.
- Reinstall OE retaining clip, ensuring the rounded edge faces valve stop.

2. Installation & Assembly

- Fit PTFE seal into groove on the end of the Sonnax replacement valve.
- Lubricate valve and PTFE seal with Sonnax slippery stick O-LUBE.
- Resize the PTFE seal by carefully inserting the valve backward into the outer portion of the bore and stroking it numerous times.

3. Final Testing

Vacuum testing at the port(s) indicated holds the recommended minimum 18 in-Hg (**Figure 2**).

