

GM 4L60-E, 4L65-E, 4L70-E

Oversized Accumulator Pin

Part No.
77754-01K

- Accumulator Pins (4)

Oversized Accumulator Pin & Reamer Kit

Part No.
77754-02K

- Accumulator Pins (10)
- Reamer

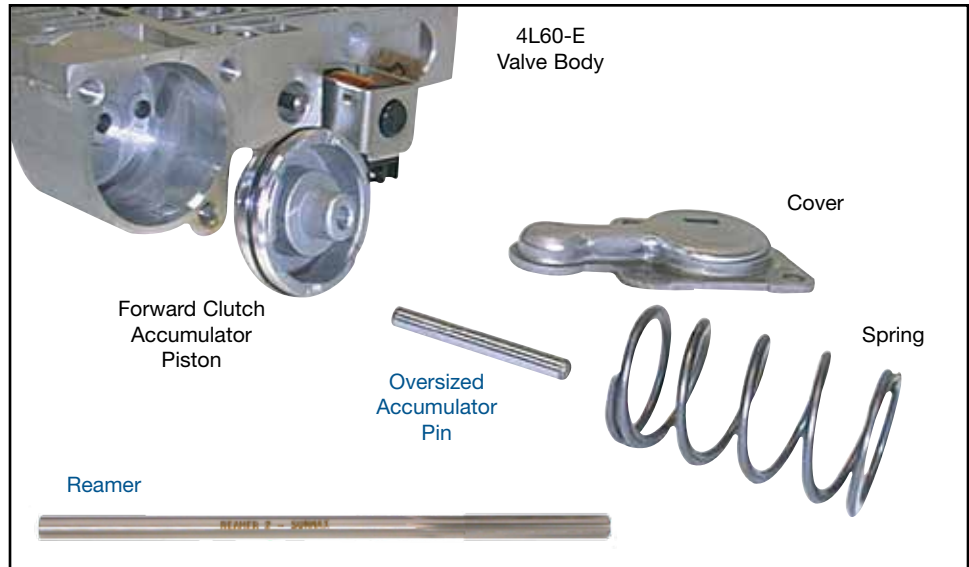

1. Disassembly

- Remove OE worn Forward clutch accumulator piston and pin from the valve body bore.
- Discard OE pin.

2. Bore Reaming Options

- Ream Forward clutch accumulator piston bore with Sonnax reamer included in 77754-02K (for reaming instructions/reamer care, please visit www.sonnax.com).
- Ream Forward clutch accumulator piston bore with 1/4" straight fluted solid carbon steel hand reamer with tolerance of .0000–.0002" +/-.

3. Installation & Assembly

- Be certain all debris has been removed from the valve bore and valve body.
- Install Sonnax pin, small diameter first, into the valve body bore until it exits the back of the hole and seats against the casting (Figure 1).

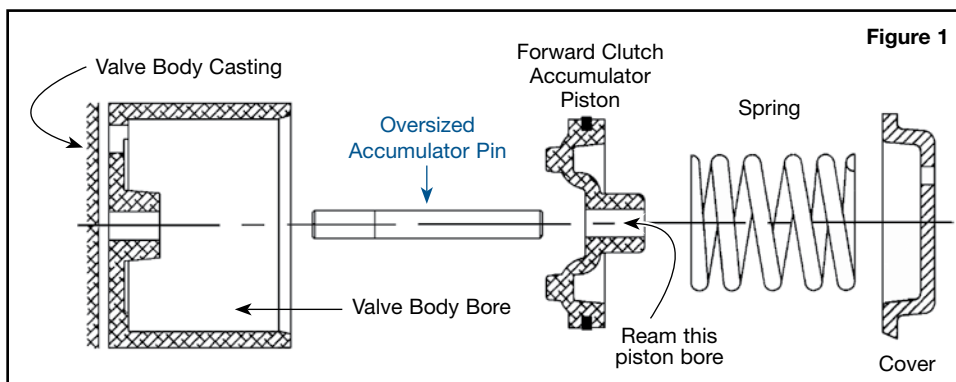

- Reinstall OE Forward clutch accumulator piston with new seal (*not supplied*), spring, cover and retaining bolts.