

Oversized Low Pressure Control Valve Kit



Part No.

55211-17K

- Valve
- End Plug

Tool Kit



Part No.

F-55211-TL17

- Reamer
- Reamer Jig
- Guide Pin

NOTE: Sonnax “F-Tool” kits designed to service a specific bore require the VB-FIX, a self-aligning valve body reaming fixture. More information and instructions can be found online at www.sonnax.com.

GM 5L40-E, 5L50-E

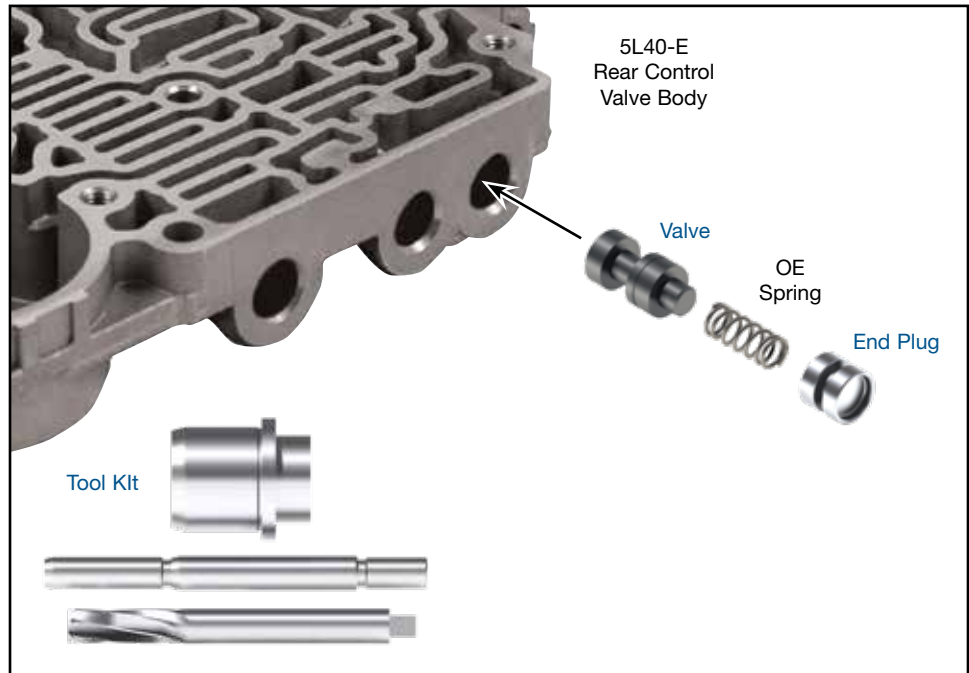

1. Disassembly

- Remove the OE retaining clip, end plug, spring and valve from bore.
- Discard the OE valve and end plug, but keep the OE spring and retaining clip for reuse.

2. Bore Reaming

Ream low pressure control bore (for reaming instructions/reamer care, please visit www.sonnax.com). Sonnax reaming tool kit **F-55211-TL17** and **VB-FIX** are required for this operation.

3. Installation & Assembly

- Be certain all debris has been removed from the valve bore and valve body.
- Install Sonnax valve into the reamed bore with the large spring stem facing outboard.
- Return the OE spring to bore, placing over the valve stem.
- Install the Sonnax end plug and retain using the OE retaining clip.

4. Final Testing

Vacuum testing at the port(s) indicated holds the recommended minimum 18 in-Hg.

