

Pressure Reducing Valve Kit

Part No.
84741-10K

- Sleeve
- Valve
- Spring
- Retaining Clip



Tool Kit

Part No.
F-84741-TL10

- Reamers (2)
- Reamer Jig
- Guide Pin

NOTE: Sonnax “F-Tool” kits designed to service a specific bore require the VB-FIX, a self-aligning valve body reaming fixture. More information and instructions can be found online at www.sonnax.com.



Hyundai/Kia A4CF1, A4CF2

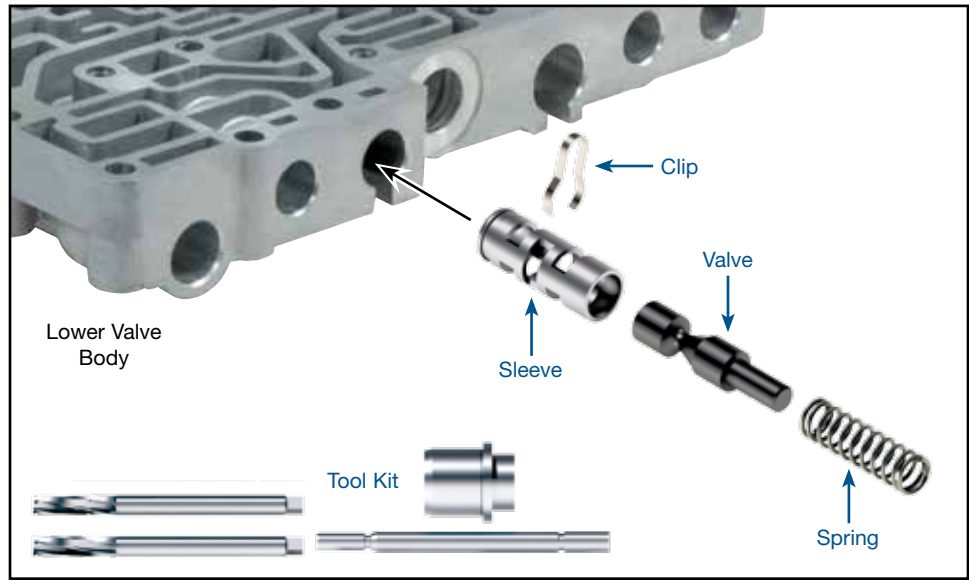

NOTE: Keep OE setting of the adjuster plug to maintain OE solenoid feed pressure. Turning the adjusting nut clockwise will reduce the gap setting, lowering solenoid pressure. Turning the adjusting nut counter-clockwise will increase the gap setting, increasing solenoid feed pressure

1. Disassembly

- Remove and discard OE pressure reducing valve and spring.
- Keep the OE retaining clip and adjustable end plug for reuse.

2. Bore Preparation

- Clean the bore thoroughly in a solvent tank.
- Generously lubricate the bore and reamer with cutting fluid (i.e. Mobilmet S-122, Lubgard[®] Bio-Tap, Tap Magic[™], etc.). For best results, provide a continuous flow of water-soluble cutting fluid (i.e. Mobilmet S-122) during the reaming process.
- The reamers should be turned using a low RPM, high-torque air drill regulated to a maximum of 200 RPM.

- Examine the bore after cleaning for surface finish, debris and burrs. Flashing and burrs on the exit side of land and in bores must be carefully removed. A small piece of Scotch-Brite[™] material attached to a wire and powered with a drill motor is ideal for the task. Scotch-Brite[™] is a very abrasive material and all residual debris must be cleaned to ensure particles do not migrate or remain imbedded into the surface. Post cleaning involves several progressive steps with solvent on a lint-free rag.

CAUTIONS AND SUGGESTIONS:

- Turning the reamer backward will dull it prematurely.
- Pushing on the reamer will result in poor surface finish and inadequate and sporadic material removal.
- Never use a crescent wrench, ratchet or pliers to turn the reamer.
- A dull reamer will cut a smaller hole. Reamers can be sharpened, but should only be done by a professional tool sharpener. Actual life of a Sonnax reamer before resharpening or replacing averages 50-70 bores.

3. Bore Reaming

Use the associated “F-Tool” F-84741-TL10 kit and VB-FIX reaming fixture as illustrated below to ream the bore.

IMPORTANT NOTE: This tool kit F-84741-TL10 contains two reamers. It is important to ream with F-84741-RM10 first and F-84741-RM11 second. Do NOT loosen clamp or wing nuts until after the second reaming.

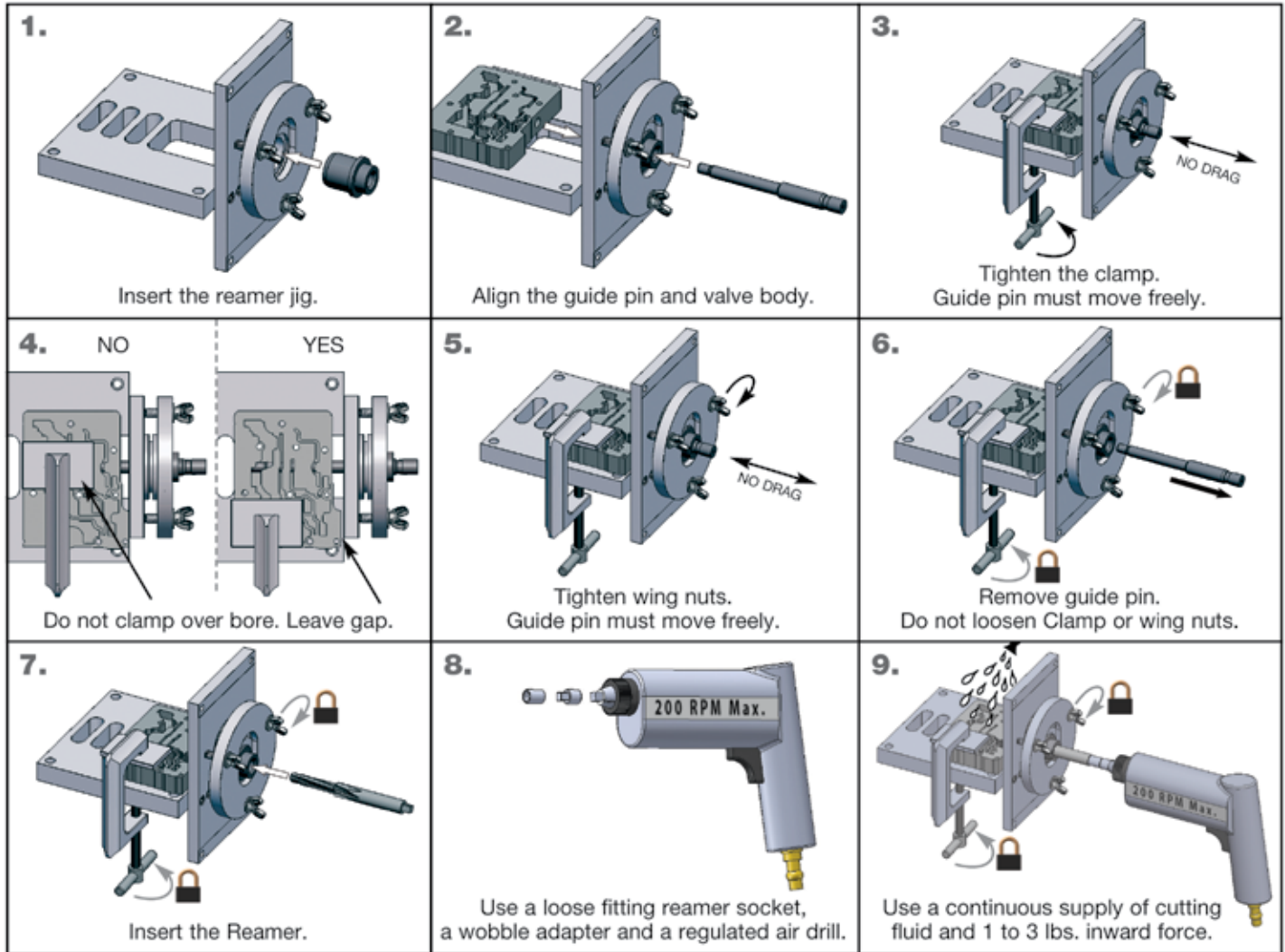

4. Installation & Assembly

- Install the Sonnax sleeve and valve into the bore with the grooved end of the sleeve inboard and valve spring stem facing outboard as pictured.
- Rotate the sleeve so that the circuit ports are facing upward, toward the separator plate.
- Install the Sonnax retaining clip in the sleeve groove, accessed through the balance port.
- Install the Sonnax spring.
- Reinstall the OE adjustable end plug and retaining pin.

5. Final Testing

A vacuum test at the port indicated holds 18 in-Hg or more.

